

Programmes After Market Services NHM-3 Series Transceivers

Trouble Shooting

Table of Contents

	Page No
Trouble Shooting	1
Trouble Shooting.....	4
Baseband	4
Phone is totally dead	5
Flash programming doesn't work	6
Power doesn't stay on, or phone is jammed	9
Display Information: "Contact Service"	10
The phone doesn't register to the network or phone doesn't make a call.....	11
Phone register failure	11
SIM related faults	14
Charger failure	17
RF Troubleshooting	18
Introduction	18
RF Measurement points	20
HAGAR RF Can	21
Abbreviations in fault finding charts	22
RF in general.....	23
EGSM Receiver	24
General instructions for EGSM RX troubleshooting	24
Fault finding chart for EGSM receiver	26
EGSM Signal path	26
RX/TX Switch.....	27
Front-end	27
Hagar	27
PCN Receiver.....	28
General instructions for PCN RX troubleshooting	28
Fault Finding Chart for PCN receiver	29
PCN Signal Path	30
Front-end	30
Hagar	30
EGSM Transmitter.....	31
General instructions for EGSM TX troubleshooting	31
Path of the transmitted EGSM signal	31
Faultfinding Chart for EGSM transmitter	32
PCN Transmitter	33
Path of the transmitted PCN signal.....	33
General instructions for PCN TX troubleshooting	33
Fault finding chart for PCN transmitter	34
Synthesiser	35
General instructions for Synthesiser troubleshooting	35
26 MHz reference oscillator (VCTCXO)	35
VCO	35
Fault finding chart for PLL Synthesiser	36
PLL Block diagram	37
Frequency lists	38
EGSM.....	38
PCN	39

Wintesla Tuning.....40
 Which RF to tune after repairs40
 RX Calibration41
 RX Filter Calibration (Automatic)44
 RX AM Suppression (Automatic)46
 TX Power tuning50
 EGSM..... 50
 PCN..... 52
 TX I/Q Tuning54
 Initial set-up EGSM 54

List of Figures

Fig 1 Phone is Totally Dead6
 Fig 2 Flash programming doesn't work.....8
 Fig 3 Flash Programming9
 Fig 4 Power doesn't stay on, or phone is jammed10
 Fig 5 Wintesla Snapshot of MCU Self-tests11
 Fig 6 Phone register failure.....12
 Fig 7 Phone doesn't register to the network14
 Fig 8 SIM related faults15
 Fig 9 SIM card rejected fault (2)16
 Fig 10 Audio faults17
 Fig 11 Charger failure18
 Fig 12 RF Function Diagram24
 Fig 13 Transmitted EGSM signal32

Trouble Shooting

Baseband

The following hints should make it easier to find the cause of the problem when the circuitry seems to be faulty. This trouble shooting instruction is divided into the following sections:

1. Phone is totally dead
2. Flash programming doesn't work
3. Power doesn't stay on or the phone is jammed
4. Display information: "Contact Service"
5. Phone doesn't register to the network or phone doesn't make a call.
6. SIM card is out of order ("insert SIM card" or "SIM card rejected")
7. Audio fault
8. Charging fault

The first thing to do is carry out a through visual check of the module. Ensure in particular that:

There are not any mechanical damages

Soldered joints are OK

FPC connector is properly closed

Phone is totally dead

This means that phone doesn't take current at all when the power switch is pressed or when the watchdog disable pin (WDDIS, X200 pin 11 or J102) is grounded. Nominal supply (VBAT voltage) to phone is 3.6V.

The hardware of CCONT (N102) prevents totally to switch power on if VBAT is below 3.1V.

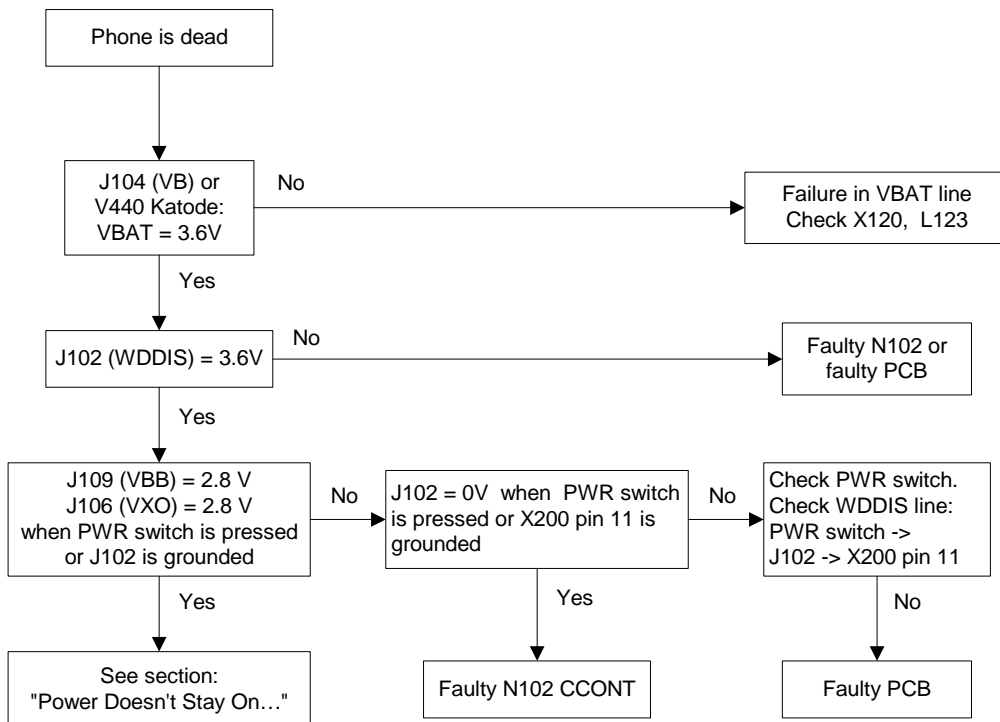

Figure 1: Phone is Totally Dead

Flash programming doesn't work

The flash programming is done via the system connector X100.

The faultfinding diagrams for flash programming are shown in figures 2 and 3.

In flash programming error cases the flash programmer can give some information about a fault.

The fault information messages could be:

- MCU doesn't boot
- Serial clock line failure
- Serial data line failure
- External RAM fault
- Algorithm file or alias ID don't find
- MCU flash Vpp error

The fault-finding diagrams for flash programming are shown in the following pages.

Because of the use of BGA components it is not possible to verify if there is a short circuit in control and address lines of the MCU (MAD2) and memory (SRAM and flash).

Flash programming (1)

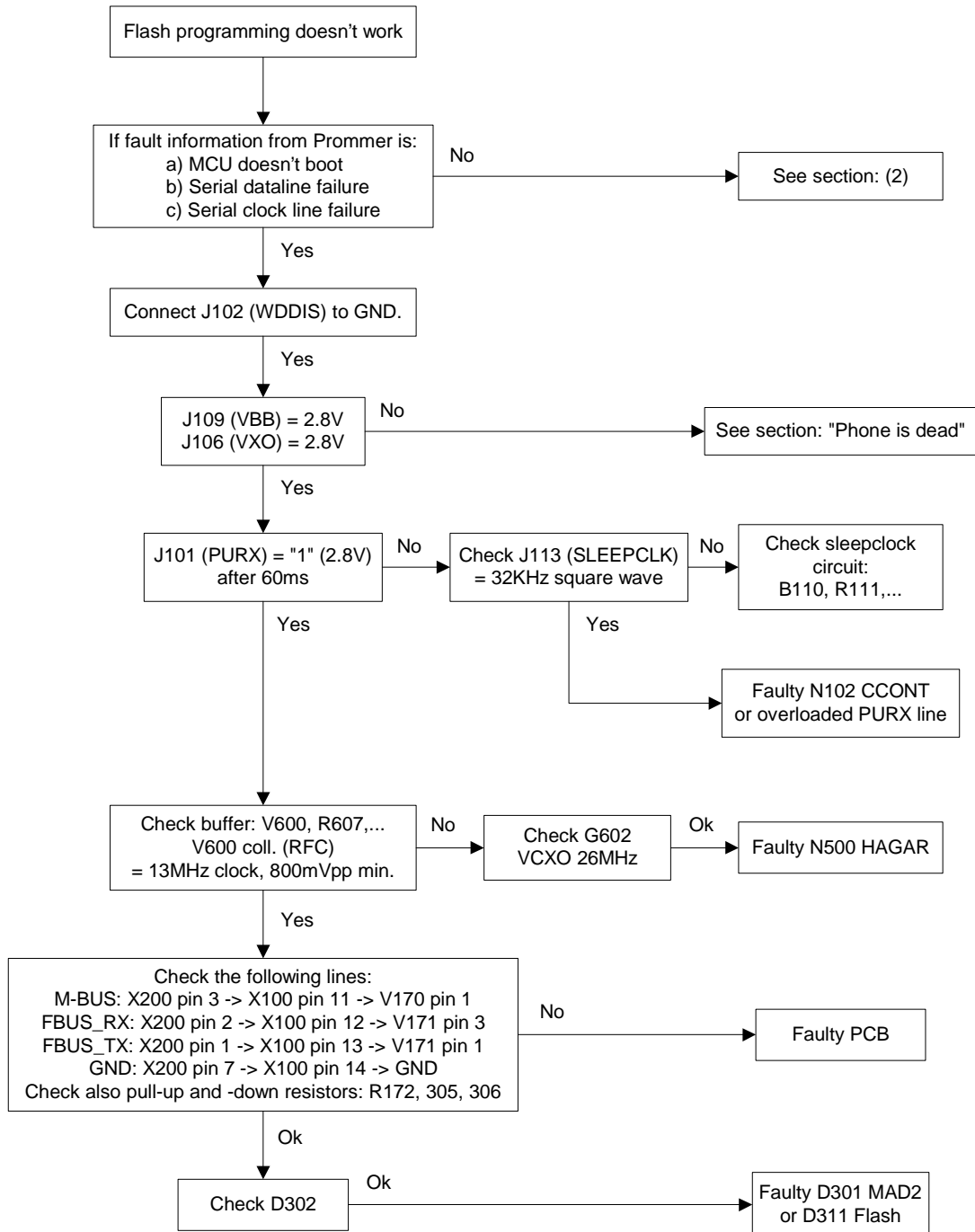

Figure 2: Flash programming doesn't work

Flash programming (2)

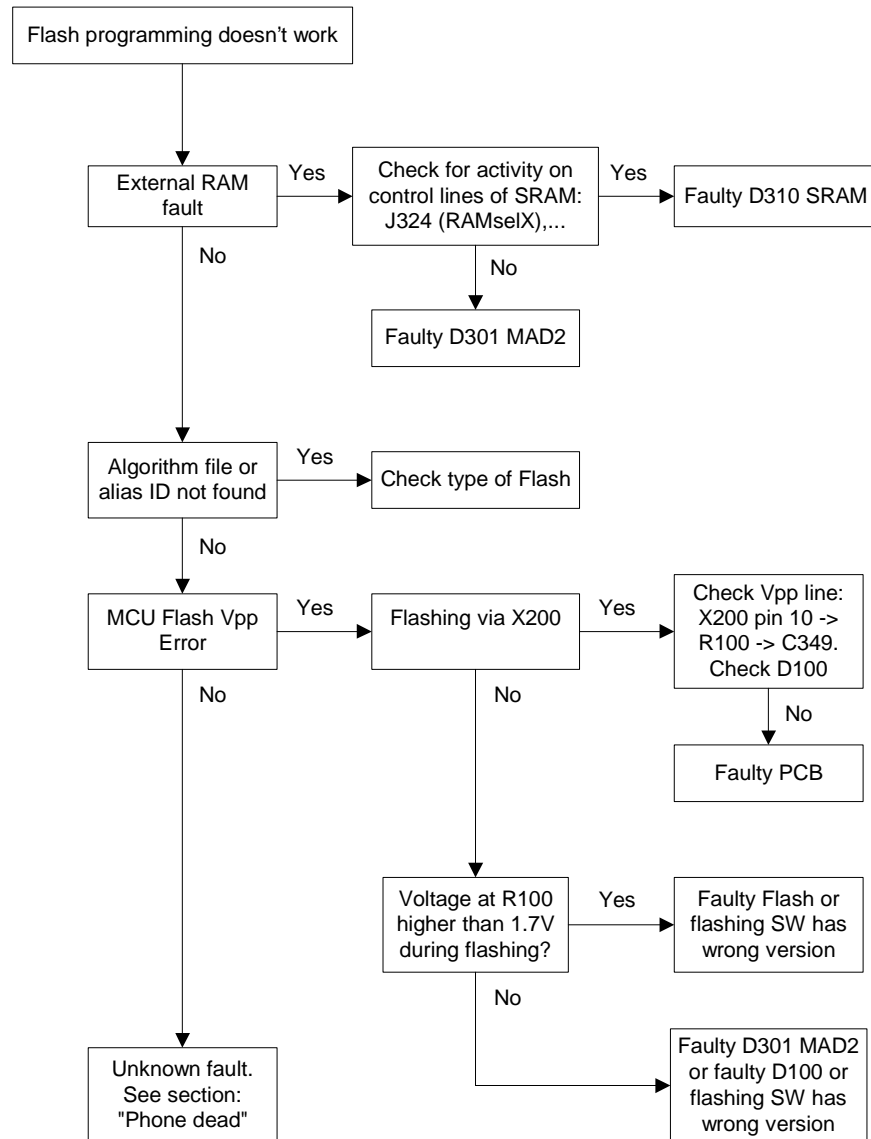

Figure 3: Flash Programming

Power doesn't stay on, or phone is jammed

If this kind of fault has come after flash programming, there are most probably open pins in ICs.

Normally the power will be switched off by CCONT (N102) after 30 seconds, if the watchdog of the CCONT can not be served by software.

The watchdog updating can be seen by oscilloscope at J103 (DataSelX from CCONT).

In normal case there is a short pulse from "1" -> "0" every 8 seconds.

The "power off" function of CCONT can be prevented by connecting a short circuit wire from J102 to ground or by shortcircuit of the PWR switch.

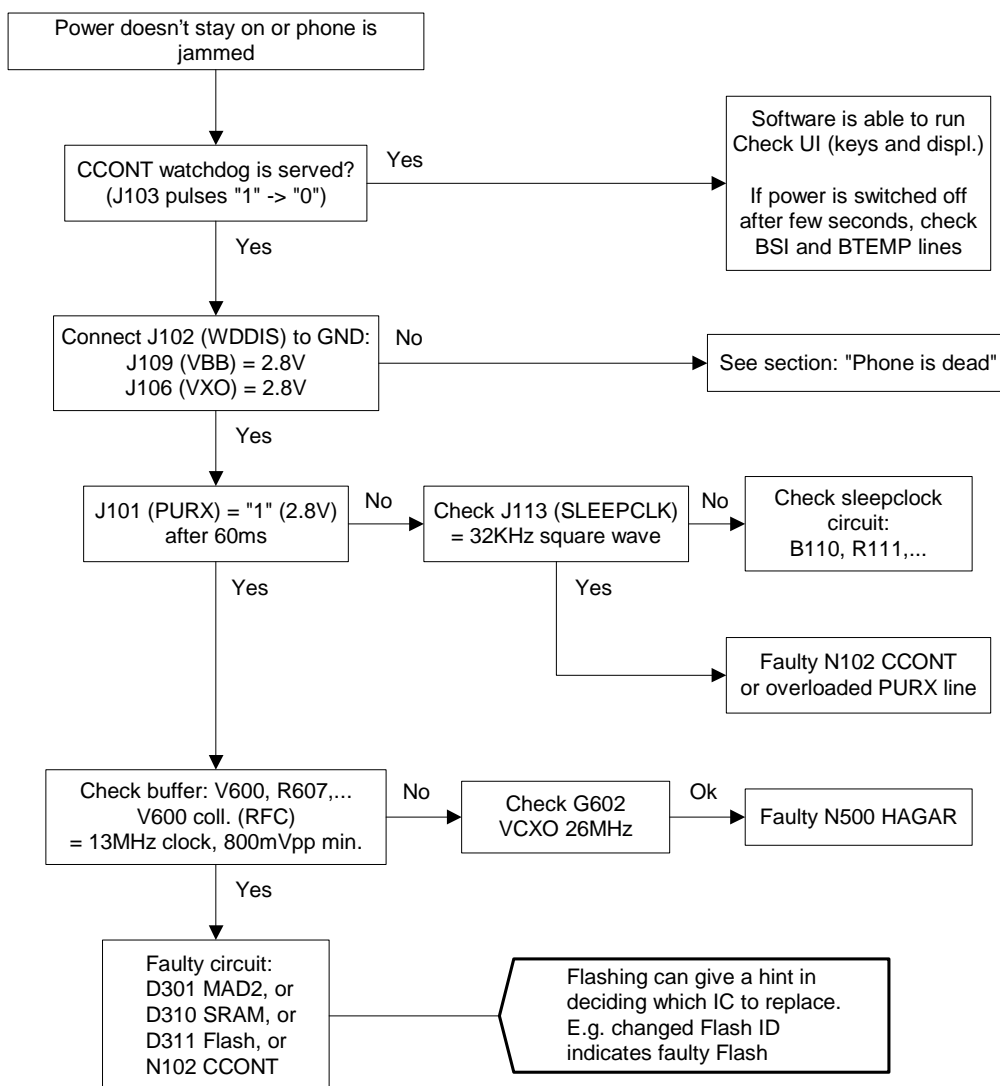

Figure 4: Power doesn't stay on, or phone is jammed

Display Information: "Contact Service"

This fault means that software is able to run and thus the watchdog of CCONT (N102) can be served.

Selftest functions are executed when power is switched on and software is started to execute from flash.

If any of the self tests is failed, the information "Contact Service" will be shown in the phone display.

MCU self tests are divided into those executed while power up (start up tests) and the ones that can be executed with connected PC. The tests and included items are as follows(screen dump from Wintesla):

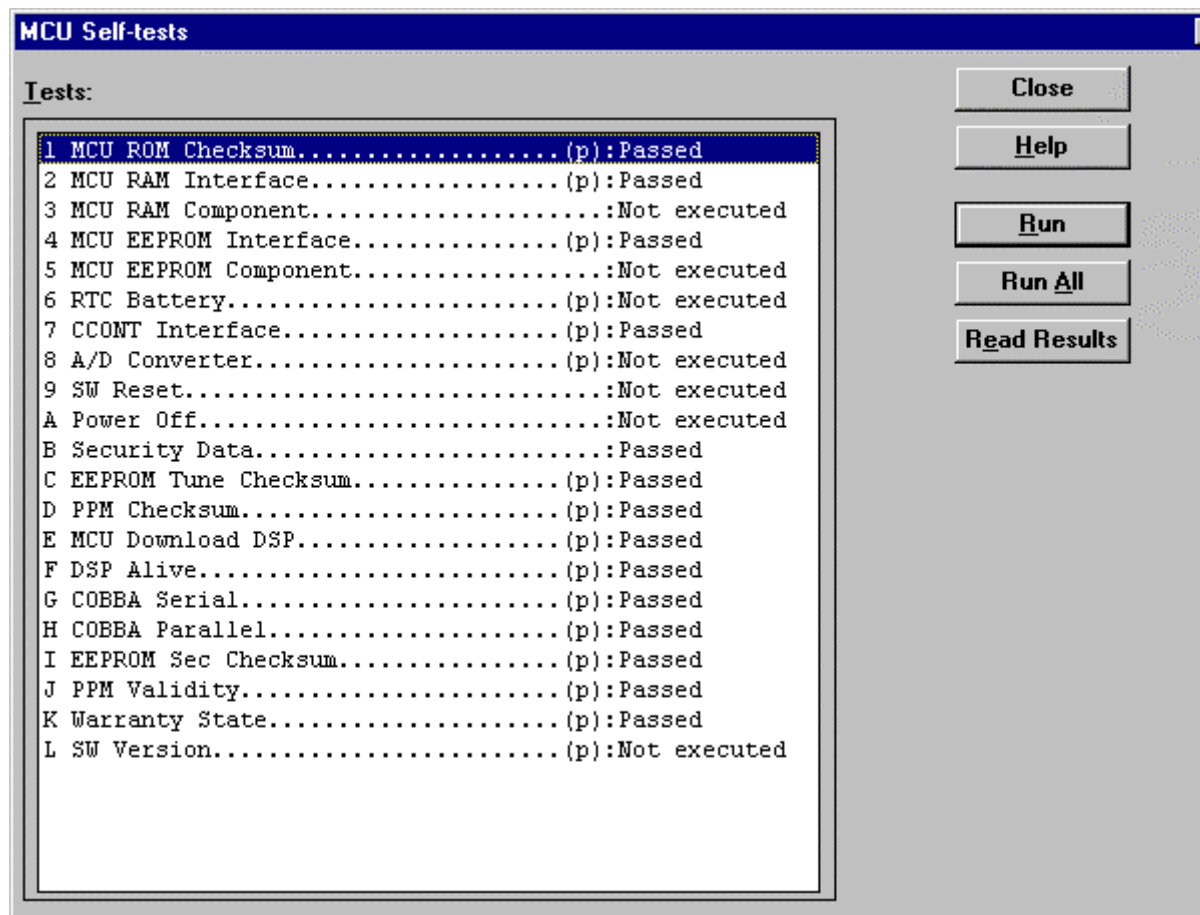

Figure 5: Wintesla Snapshot of MCU Self-tests

This information can be used for diagnosing :

Explanation for item no. 1 : MCU ROM Checksum:

Calculates 16 bit checksum out of Flash code and compares it to ones found in Flash- Items being checked are MAD2<-> Flash data and adress lines, CE0,CE1,WE, BYTE, Vcc, GND, and Flash internal functionality.

The phone doesn't register to the network or phone doesn't make a call

If the phone doesn't register to the network or the phone doesn't make a call, the reason could be either the baseband or the RF part.

The phone can be set to required mode by WinTesla service software in order to determine if the fault is in RF or in baseband part (RF interface measurements).

The control lines for RF part are supplied both the System Asic (MAD2;D301) and the RFI (Cobba, N240). MAD2 handles digital control lines (SynthEna, TxP etc.) and Cobba handles analog control lines (AFC, TxC etc.).

The DSP software is constructed so that operation states of DSP (MAD2) can be seen in external flag (DSPXF) output pin, J314.

After power up, DSP indicates all the completed functions by changing the state of the XF pin as shown in figures below

(continued on the next page , and fault finding on the page after.

Phone register failure

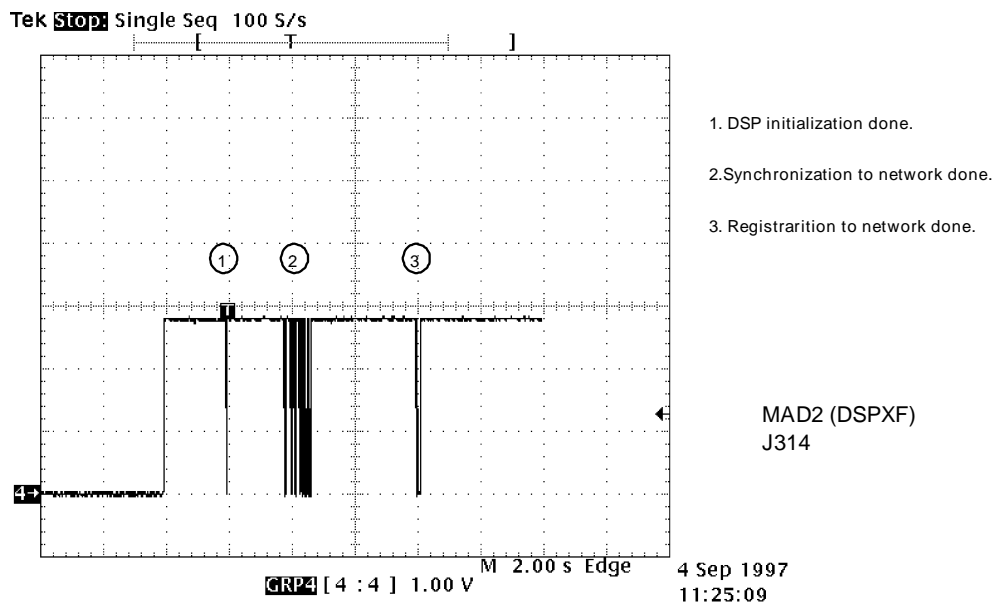
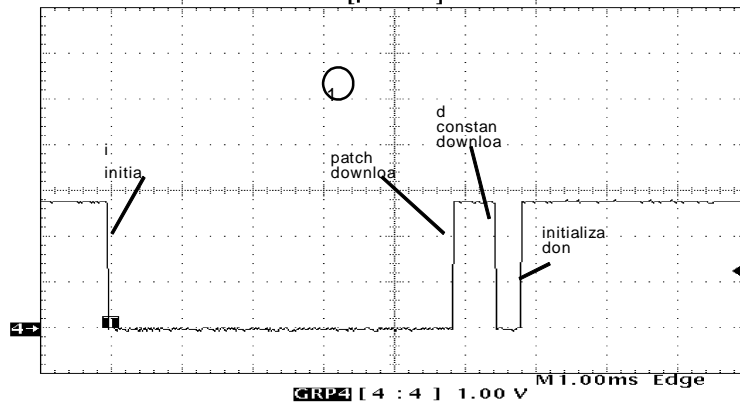

Figure 6: Phone register failure

Tek **Stop** Single Seq 50.0kS/s



MAD2 (DSPXF)
J314

4 Sep 1997
10:35:06

Tek **Stop** Single Seq 500 S/s

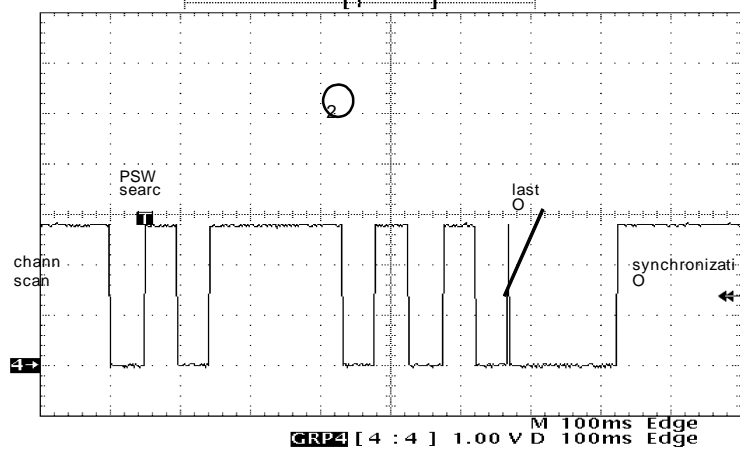

MAD2 (DSPXF)
J314

4 Sep 1997
11:36:49

Tek **Stop** Single Seq 500 S/s

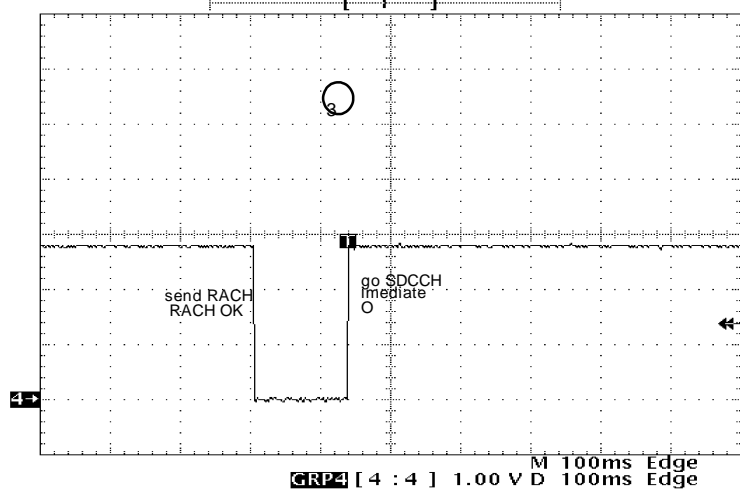

MAD2 (DSPXF)
J314

4 Sep 1997
12:00:14

Phone doesn't register to the network...

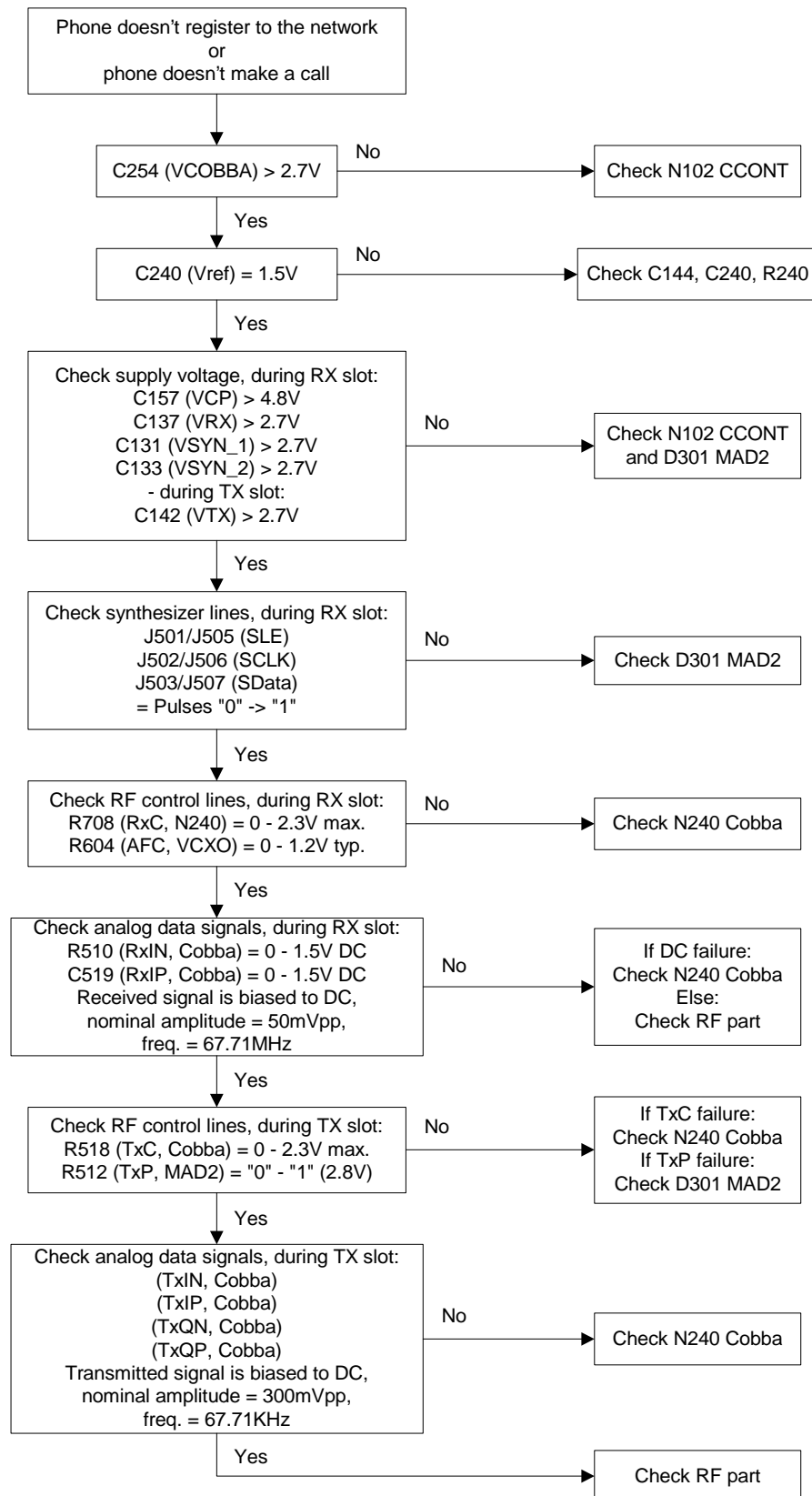

Figure 7: Phone doesn't register to the network

SIM related faults

The hardware of the SIM interface from MAD2 (D301) to the SIM connector(X160) can be tested without a SIM card.

When the power is switched on and if the BSI line (X120) is grounded by a resistor, all the used lines (VSIM,DATA, RST, CLK) rise to 3V and then 5V (the phone will try this four times). Thus "Insert SIM card" faults can be found without a SIM card.

The fault information "SIM card rejected" means that the ATR message (the first message is always sent from card to phone) is sent from card to phone but the message is somehow corrupted, data signal is wrong etc, or factory set values (stored to the emulated EEPROM) are not correct.

Insert SIM card fault (1)

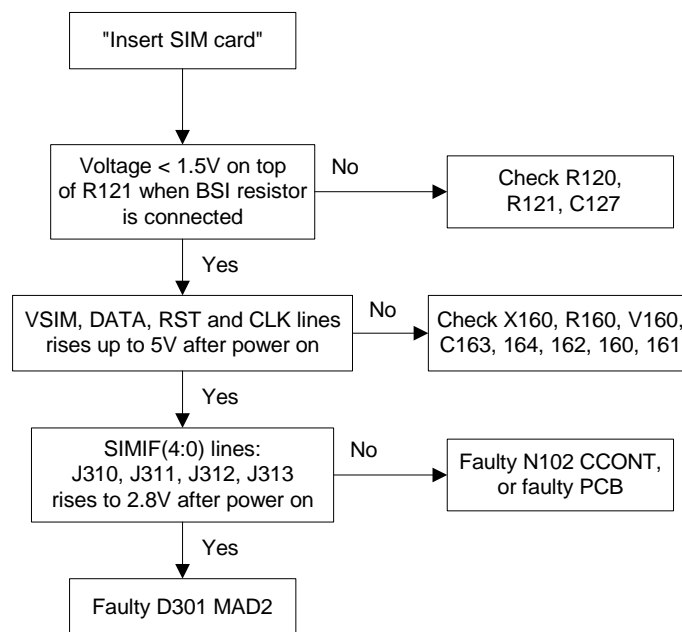

Figure 8: SIM related faults

SIM card rejected fault (2)

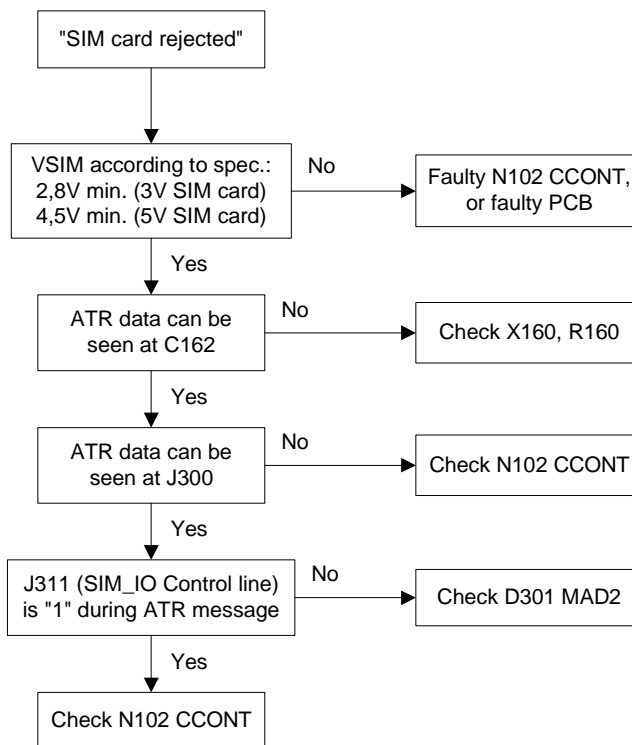

Figure 9: SIM card rejected fault (2)

Audio faults

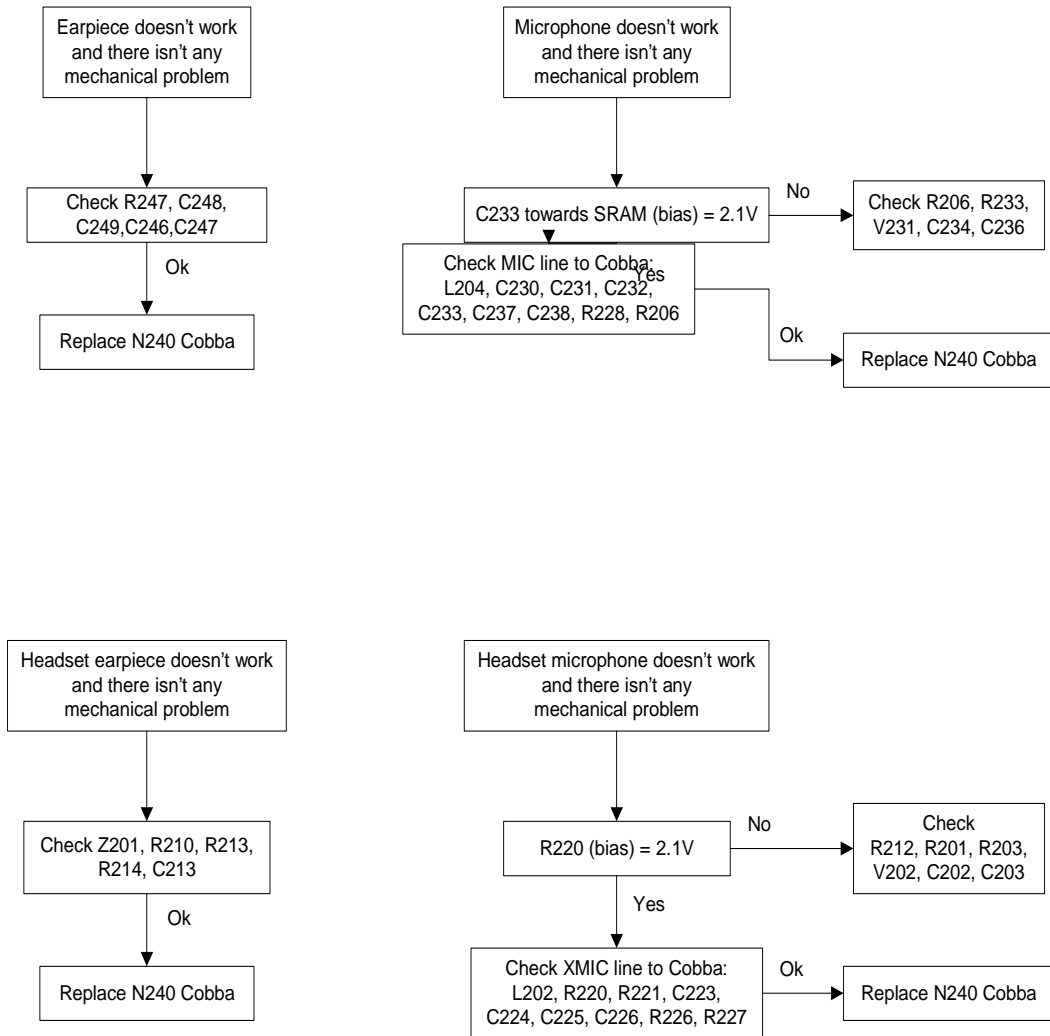

Figure 10: Audio faults

Charger failure

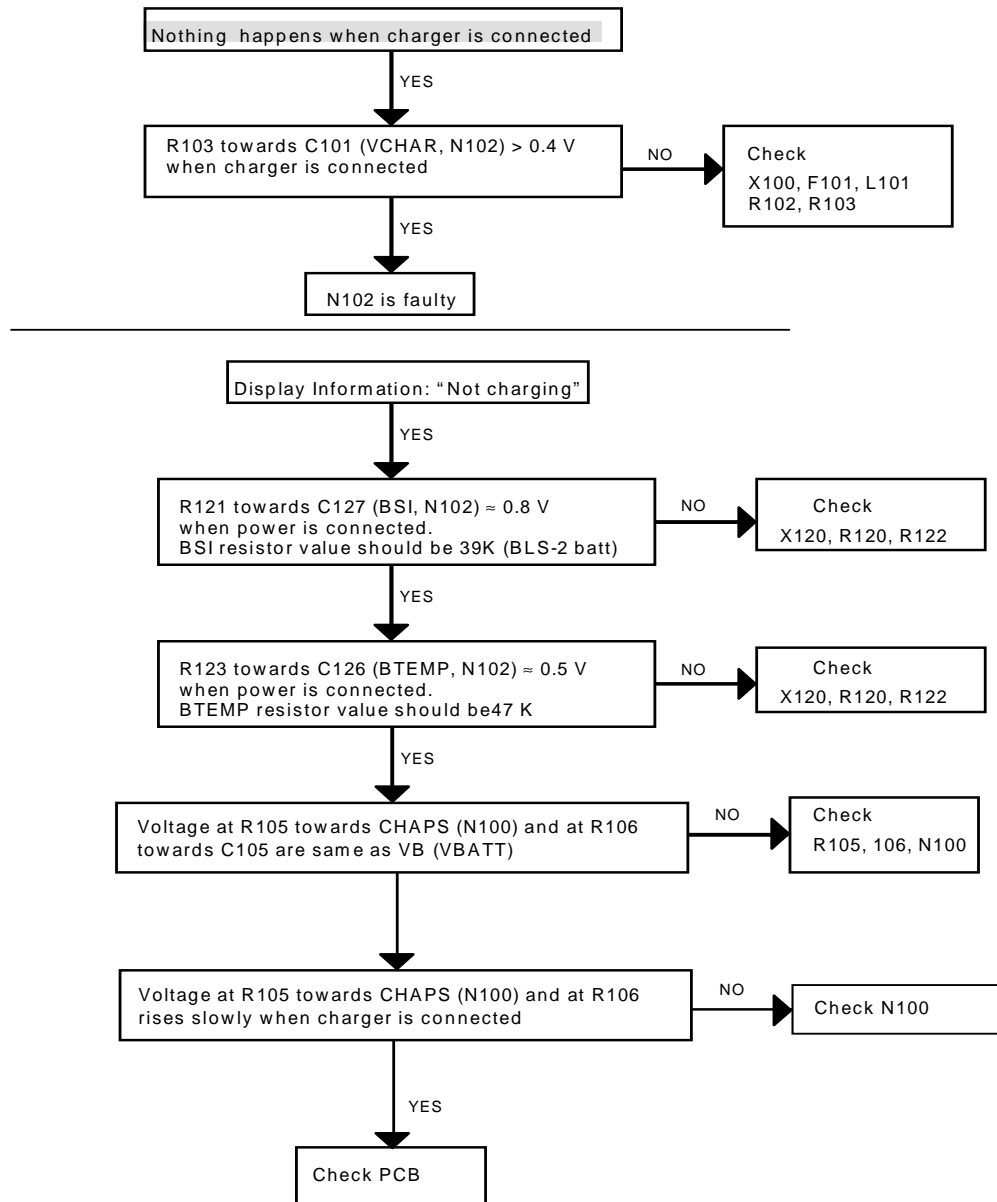

Figure 11: Charger failure

RF Troubleshooting

Introduction

Measurements should be done using Spectrum Analyzer with high-frequency 500 ohm passive probe (LO-/reference frequencies and RF-power levels) and Oscilloscope with a 10 probe (DC-voltages and low frequency signals).

The RF-section is built around one ASIC Hagar (N500). For easier troubleshooting, this RF troubleshooting document is divided into sections.

Before changing Hagar, please check the following things: Supply voltages are OK and serial communication are coming to Hagar.

Grounding of the PA-module is directly below PA-module so it is difficult to check or change. **Most RF semiconductors are static discharge sensitive!** So ESD protection must be taken during repair (ground straps and ESD soldering irons). Hagar are moisture sensitive so parts must be pre-baked prior to soldering.

Apart from key-components described in this document here are a lot of discrete components (resistors, inductors and capacitors) which troubleshooting is done by checking if soldering of the component is done properly, checking if it is missing from PCB. Capacitors can be checked for shortening and resistors for value by means of an ohmmeter, but be aware in-circuit measurements should be evaluated carefully.

All measured voltages or **RF levels in this document are rough figures**. Especially RF levels varies due to different measuring equipment or different grounding of the used probe.

All tuning must be done with Wintesla support DLL's version 271.01.00 or later (dated February 3rd 2000 or later)

RF Key Component placement

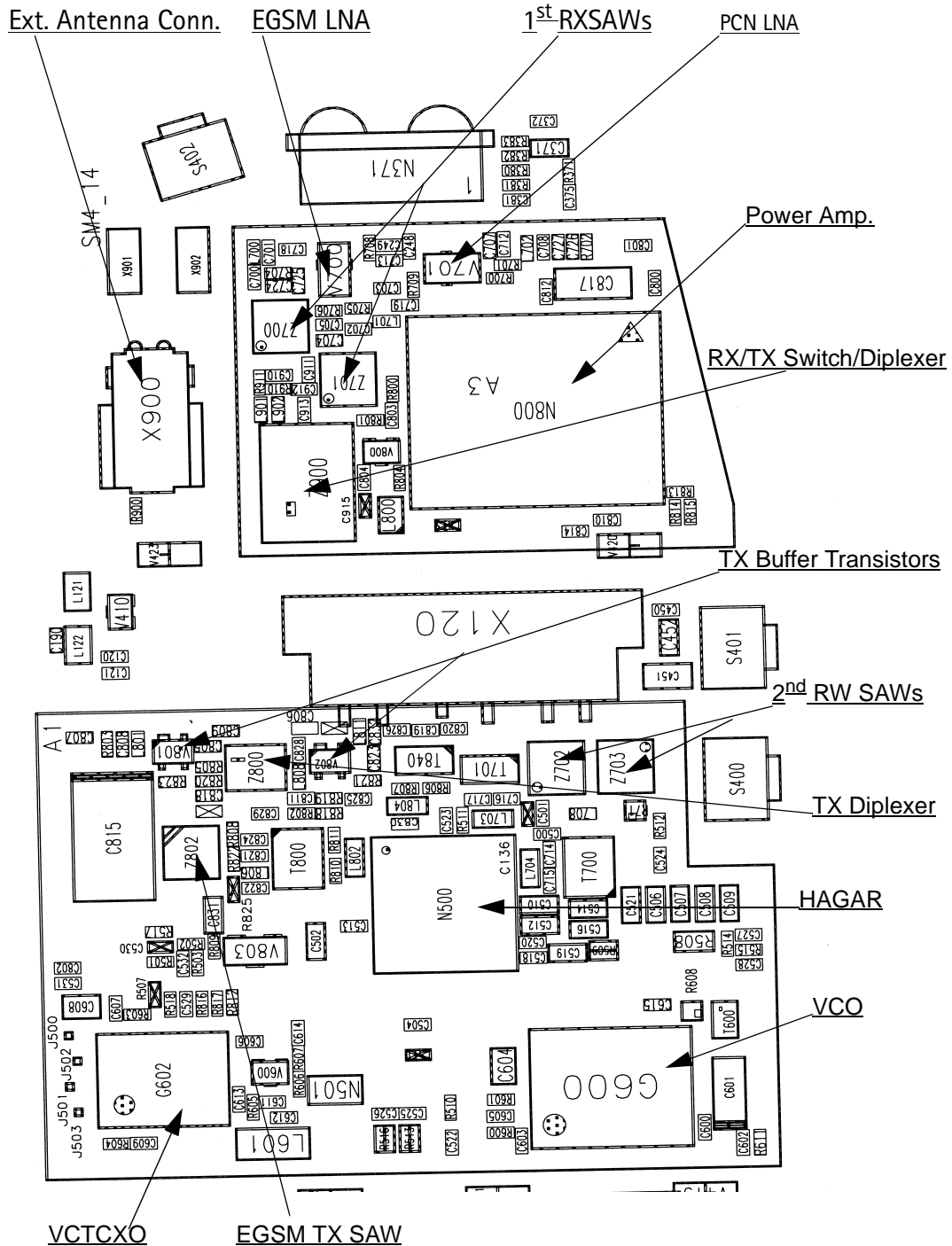

RF Measurement points

PA Can

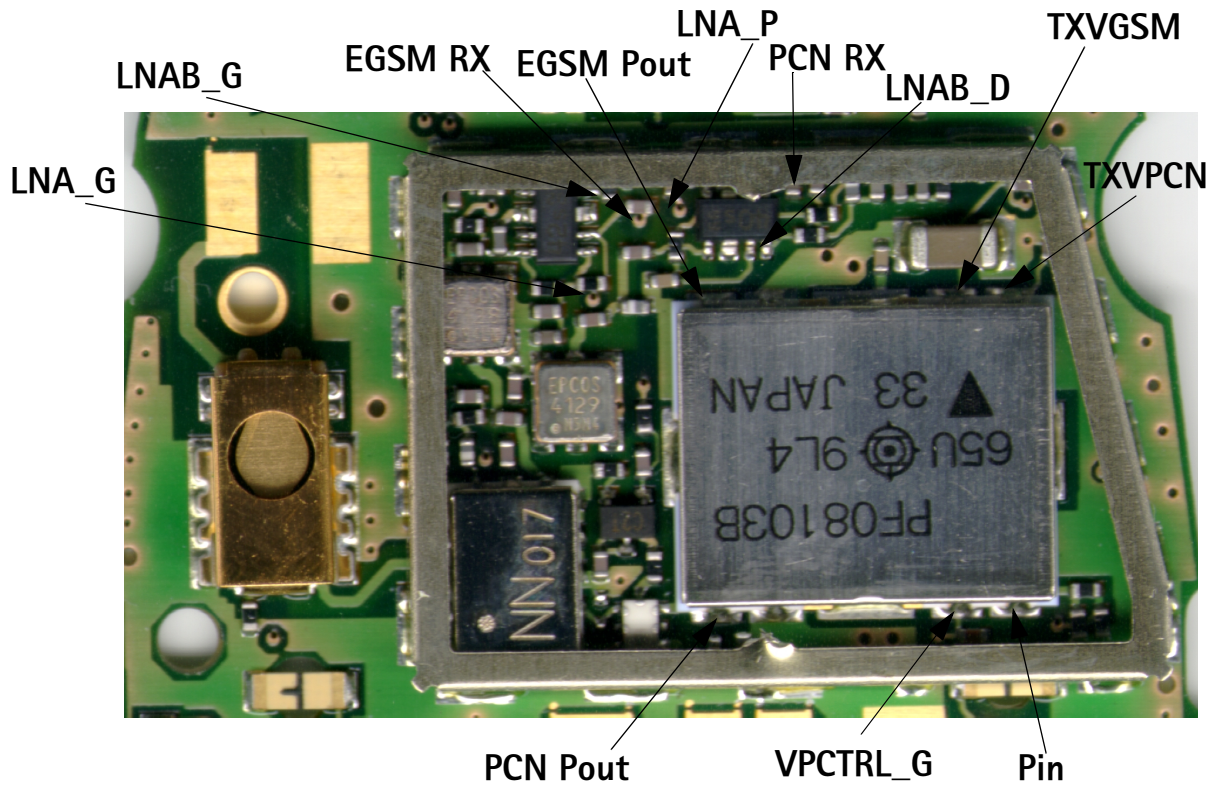

HAGAR RF Can

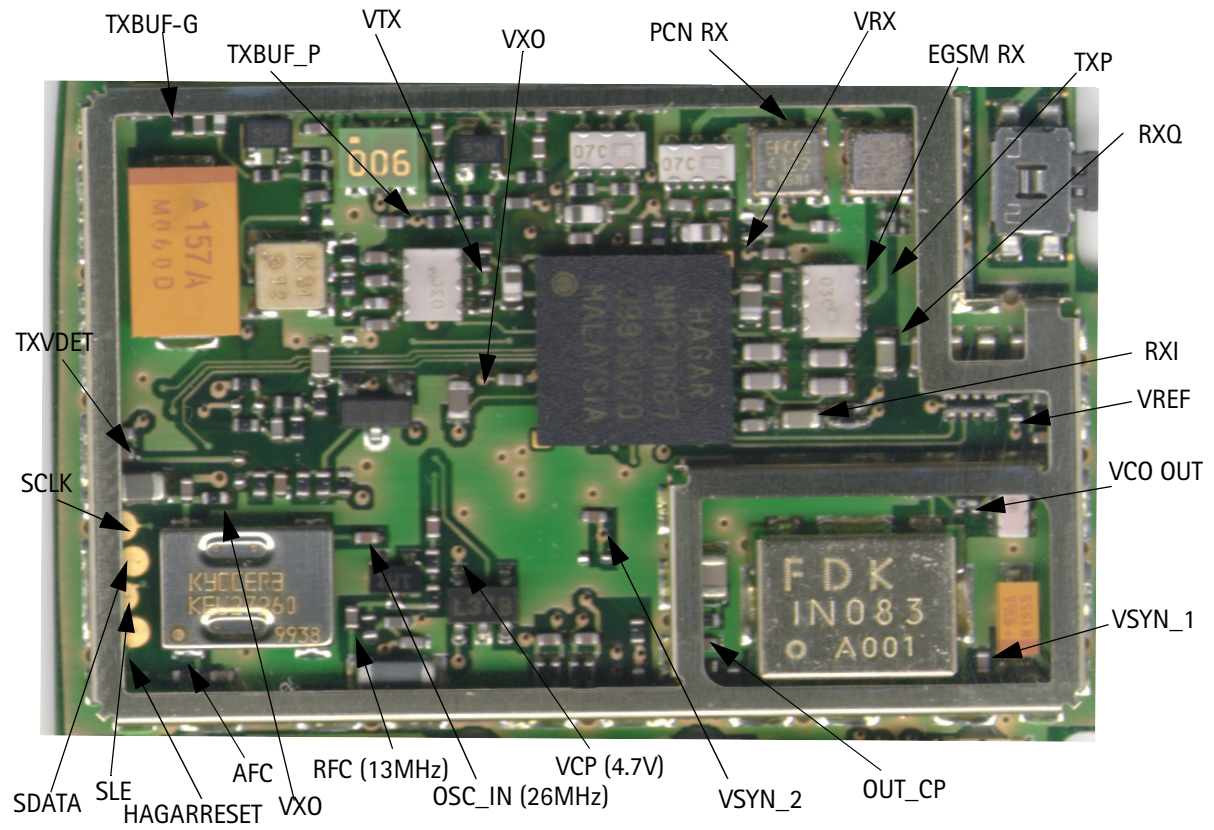

Abbreviations in fault finding charts

BB	Baseband
DC	Direct Current
ESD	Electro Static Discharge
f:	Frequency of signal (measured with Spectrum Analyzer)
LO	Local Oscillator
P:	Power of signal in decibels (dB) (measured with Spectrum Analyzer)
PA	Power Amplifier
PCB	Printed Circuit Board
PLL	Phase Locked Loop
RF	Radio Frequency
RX	Receiver
T:	Time between pulses
TX	Transmitter
UHF	Ultra High Frequency
V:	Voltage of signal (measured with oscilloscope)
VCO	Voltage controlled oscillator
VHF	Very High Frequency

RF in general

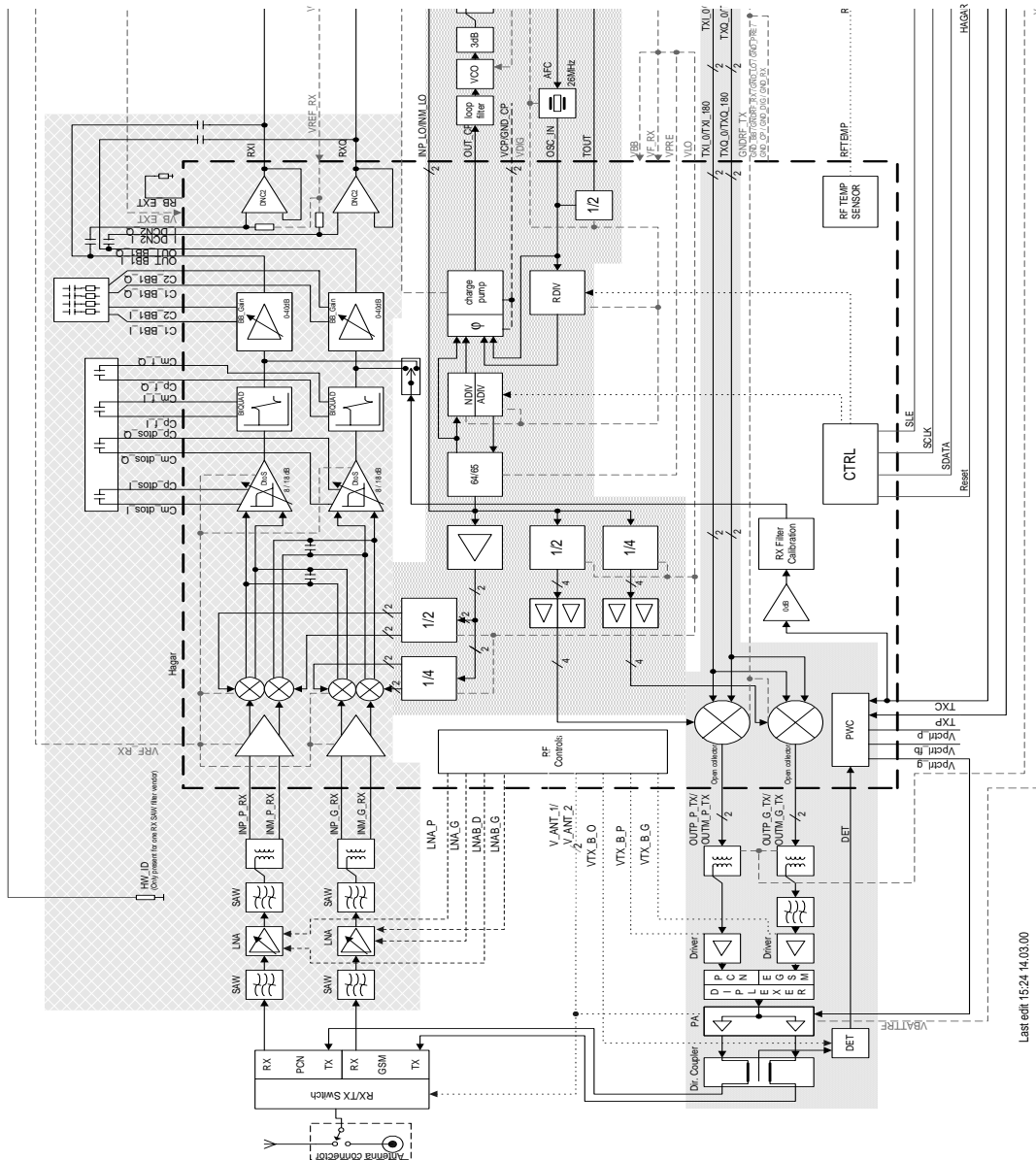

Figure 12: RF Function Diagram

RF part of this product is a direct conversion transceiver (Also used in 6210, 8210 and 8850). In direct conversion no intermediate frequencies are used for up- or downconversion. The VCO is set to either twice or four times (depending on the band used) the wanted RX or TX Frequency. The VCO frequency is divided by either 2 or 4 and fed to the mixers (down-conversion) or modulators (up-conversion). Up- or down-conversion is done in one step, directly between RF frequency and DC. All up and down-conversion takes place in the RF IC named Hagar (N500). Hagar also contains PLL and a DC control section used to power and/or control LNAs, TX buffers, Detector and RX/TX Switch. Hagar is controlled via a serial bus (CTRL).

EGSM Receiver

General instructions for EGSM RX troubleshooting

Connect the phone to a PC with a DAU-9P cable

Start Wintesla-Service-Software and

<u>Action</u>	<u>Keystrokes</u>
Select <u>P</u> roduct Open...	Alt+p
NHM-3	
Select: <u>P</u> roduct	Alt+p
<u>B</u> and	b
EGSM	e
Select: <u>T</u> esting	Alt+e
<u>R</u> F Controls	r
<u>R</u> X Continuous	Alt+r
Cont. Mode Ch: 56	Alt+o, 56
AGC Absolute: 8	
<u>M</u> ultislot on	Alt+u, if on remove checkmark
<u>A</u> pply	

The set-up should now look like this:

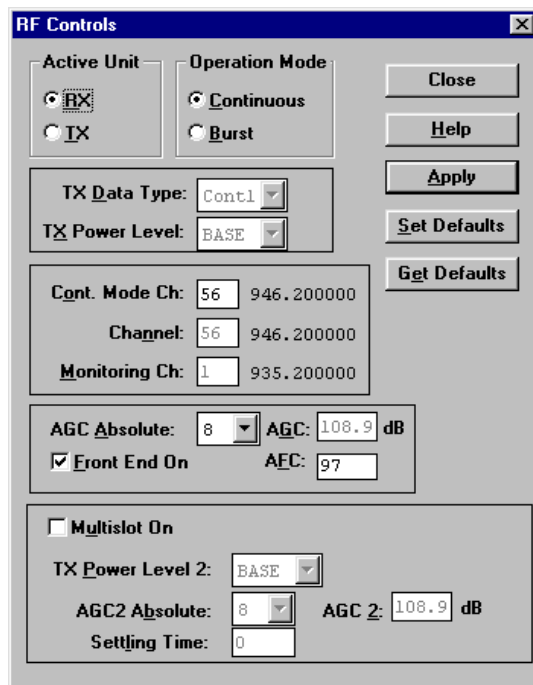

Apply a 946.267 MHz (channel 56 + 67.710kHz offset) -90 dBm signal to the RF-con-
nector (remember to compensate for cable attenuation).

Measuring with an oscilloscope on "Hagar RXI" or "Hagar RXQ" this picture should be
seen on a working EGSM receiver:

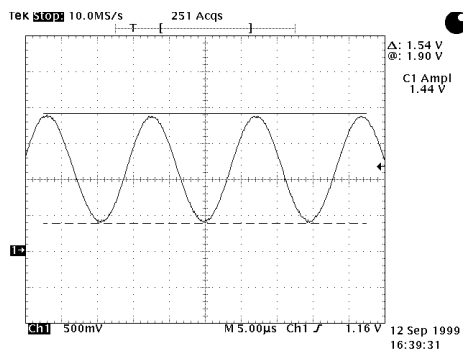

Signal amplitude	680mV*
DC offset	1,1V*
Frequency	67kHz

*Note: 1. These values are approximate and can vary between units.

2. If this picture is not seen use the following fault finding chart for EGSM
receiver.

Fault finding chart for EGSM receiver

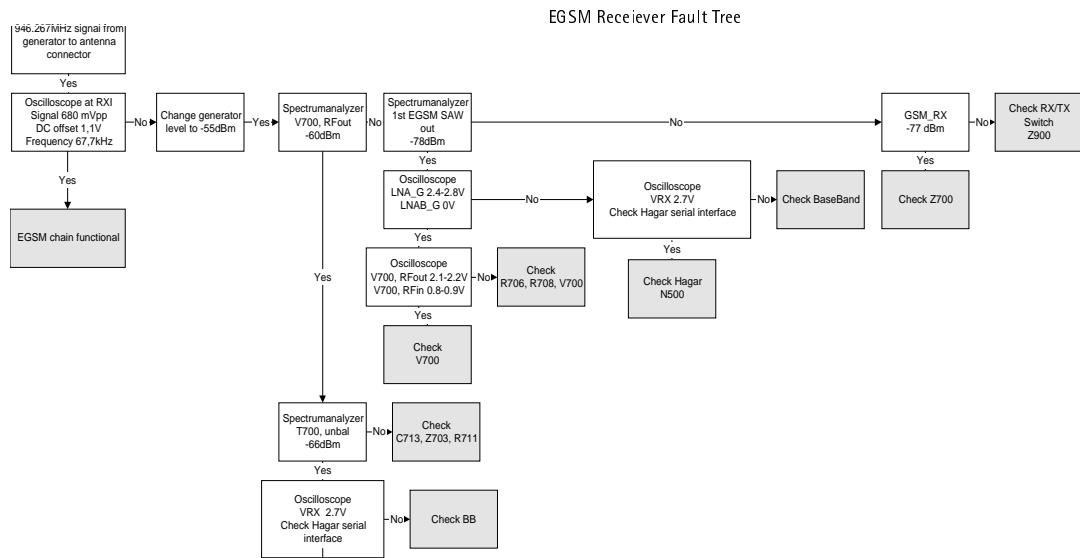

EGSM Signal path

For easy error tracing it is important to know the signal path of the EGSM receiver. The components can be grouped into blocks and drawn as shown below.

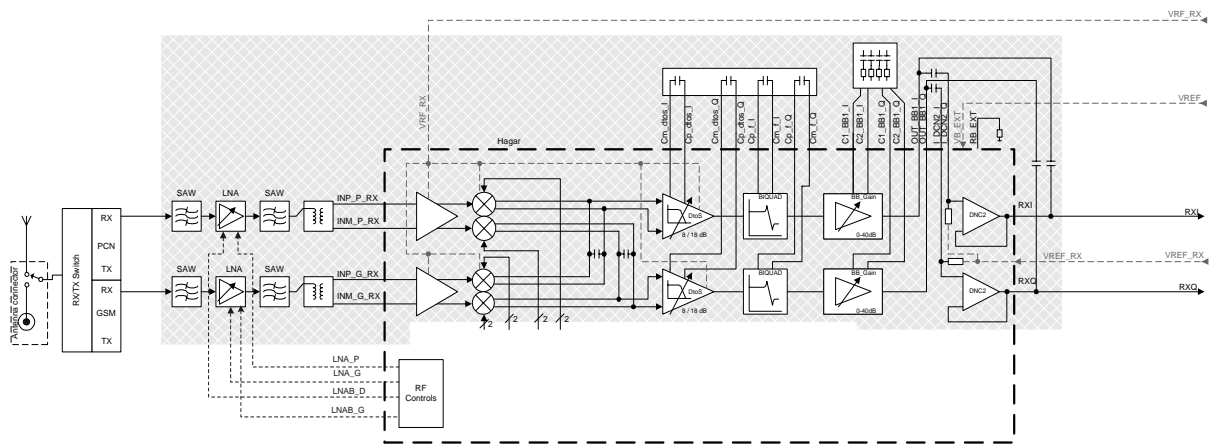

RX/TX Switch

From the antenna-pad (X901) the RF signal is lead to the RX/TX switch (Z900) via a mechanical switch, the antenna connector (X900).

The RX/TX switch is normally open to the two RX outlets GSM_Rx and PCS_Rx. If no control voltage is present at VC1 or VC2 the RX/TX switch will work as a diplexer and EGSM signals pass to GSM_Rx and PCN signals to PCS_Rx.

From GSM_Rx the EGSM signal is fed to the 1st EGSM SAW filter via C912.

Front-end

The EGSM front-end consists mainly of two SAW filters (Z700 and Z703) and one LNA (V700) in-between and finally one balun (T700). The SAW filters provides out-of-band blocking immunity, the LNA provides front-end gain and the balun provides a balanced signal for Hagar (N500)

The signal-path is Through Z700 (In-band insertion-loss 3,5dB), through the matching circuit (C700, L700 and C701) and to the EGSM LNA (V700, RFin).

The LNA has about 20dB gain when it is on (LNA_G = 2.7V and LNAB_G=0V). If the signal applied to the antenna-connector is more than -45dBm the AGC will gainstep the LNA (LNA_G = 0V and LNAB_G=2.7V) which means the LNA Gain will now have negative gain (loss).

From the LNA (V700 RF out) the signal is lead through the LNA-output-matching-circuit (R705, Z705 and C713), through the 2nd EGSM SAW Z703 (In-band insertion-loss 3,5dB) through a 3dB attenuator (R711) and to the EGSM balun T700. From the balun the signal is balanced and is lead to Hagar (N500 IMP_GSM_RX and INM_GSM_RX).

Hagar

The balanced RX signal is mixed with a signal from the local oscillator at the same frequency as the wanted RX signal. After mixing the signal is converted to a singleended signal in the DtoS (Differential to Singleended) amplifier. The signal is now filtered in a BIQUAD filter to provide channel separation, amplified in the BB_Gain amplifier and DC compensated in DCN2.

PCN Receiver

General instructions for PCN RX troubleshooting

<u>Action</u>	<u>Keystrokes</u>
Connect the phone to a PC with a DAU-9P cable	
Start Wintelsa-Service-Software and	
Select <u>P</u> roduct	Alt+p
Open...NHM-3	
Select: <u>P</u> roduct	Alt+p
<u>B</u> and	b
<u>P</u> CN	p
Select: <u>T</u> esting	Alt+e
<u>R</u> F Controls	r
<u>R</u> X Continuous	Alt+r
C <u>o</u> nt. Mode Ch: 700	Alt+o, 700
AGC Absolute: 8	
<u>M</u> ultislot on	Alt+u, if on remove checkmark
<u>A</u> pply	

The set-up should now look like this:

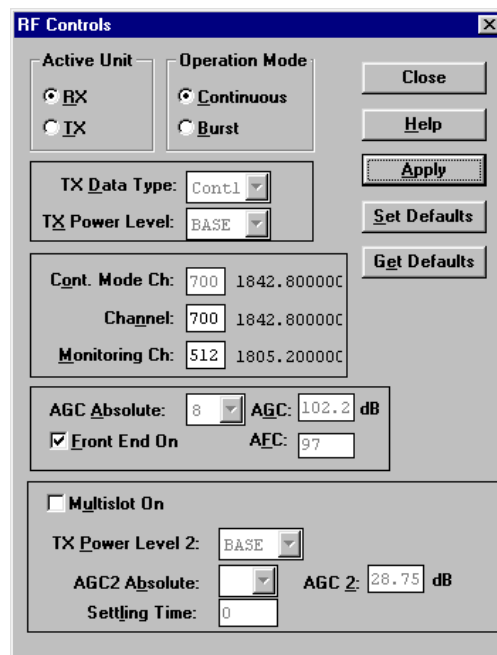

Apply a 1842.867 MHz (channel 700 + 67.710kHz offset) -90 dBm signal to the RF-con-
nector (remember to compensate for cable attenuation).

Measuring with an oscilloscope on "Hagar RXI" or "Hagar RXQ" this picture should be
seen on a working PCN receiver:

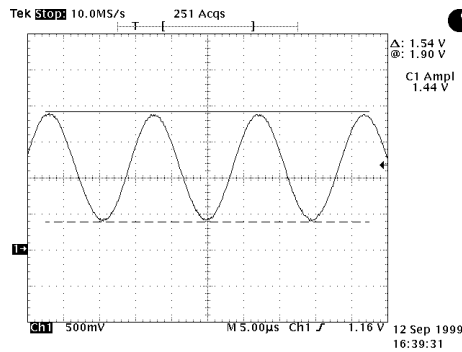

Signal amplitude 300mV*
DC offset 1,1V*
Frequency 67kHz

*Note: 1. These values are approximate and can vary between
2. If this picture is not seen use the following fault finding chart for PCN receiver

Fault Finding Chart for PCN receiver

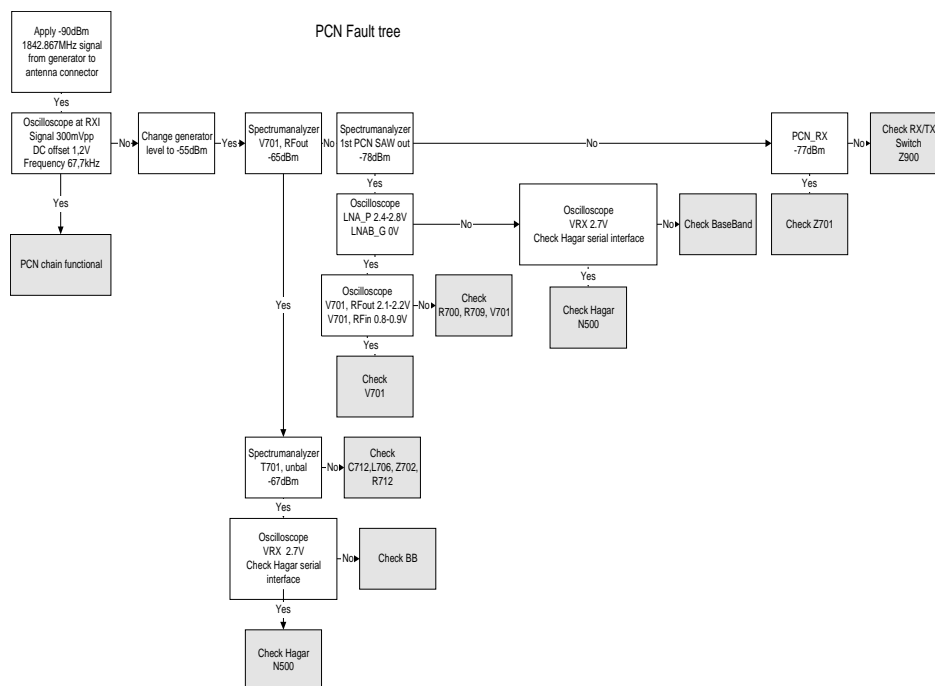

PCN Signal Path

For easy error tracing it is important to know the signal path of the PCN receiver. The components can be grouped into blocks and drawn as shown below.

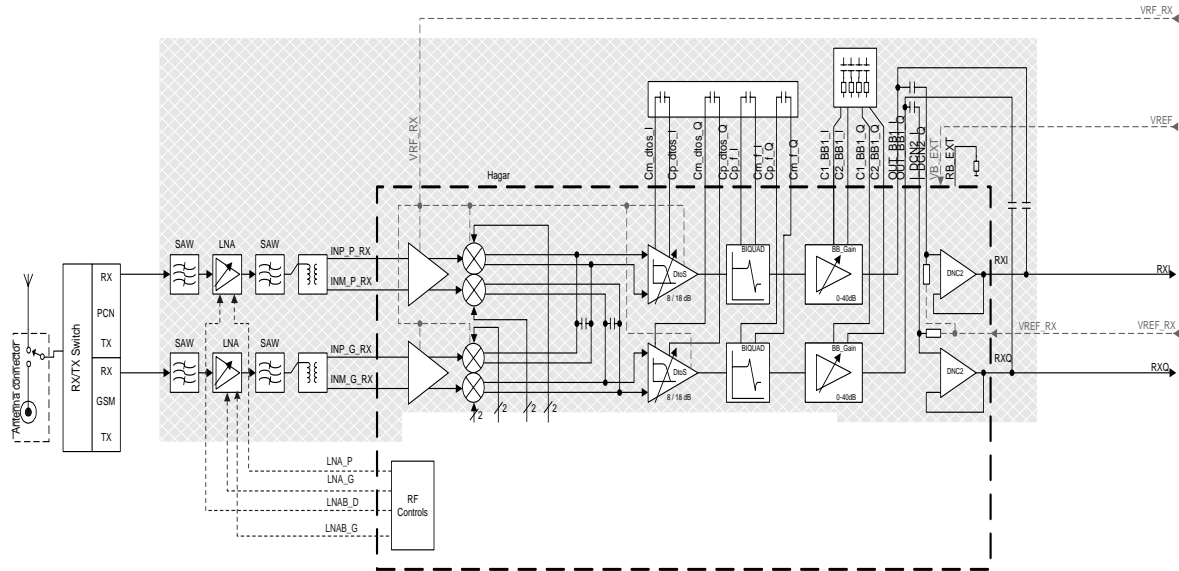

From the antenna pad (X901) the RF signal is lead to the RX/TX switch (Z900) via a mechanical switch, the antenna connector (X900).

The RX/TX switch is normally open to the two RX outlets GSM_Rx and DCS_Rx. If no control voltage is present at VC1 or VC2 the RX/TX switch will work as a diplexer and PCN signals pass to PCS_Rx and EGSM signals to GSM_Rx.

From PCS_Rx the PCN signal is fed to the 1st PCN SAW filter via C913.

Front-end

The PCN front-end consists mainly of two SAW filters (Z701 and Z702) and one LNA (V701) in-between and finally one balun (T701). The SAW filters provides out-of-band blocking immunity, the LNA provides front-end gain and the balun provides a balanced signal for Hagar (N500)

The signal-path is Through Z701 (In-band insertion-loss max 4dB), through the matching circuit (C702, L701 and C703) and to the PCN LNA (V701, RFin).

The LNA has about 16.5 dB gain when it is on (LNA_P = 0 V and LNAB_D=2.7 V). If the signal applied to the antenna-connector is more than -45dBm the AGC will gainstep the LNA (LNA_P = 2.7 V and LNAB_G=0 V) which means the LNA Gain will now have negative gain (loss).

From the LNA (V701 RF out) the signal is lead through the LNA-output-matching-circuit (R701, L702 and C712), through the 2nd PCN SAW Z702 (In-band insertion-loss max 4dB) to the PCN balun T701. From the balun the signal is balanced and is lead to Hagar (N500 IMP_PCN_RX and INM_PCN_RX).

Hagar

The balanced RX signal is mixed with a signal from the local oscillator at the same frequency as the wanted RX signal. After mixing the signal is converted to a singleended signal in the DtoS (Differential to Singleended) amplifier. The signal is now filtered in a BIQUAD filter to provide channel separation, amplified in the BB_Gain amplifier and DC compensated in DCN2.

EGSM Transmitter

General instructions for EGSM TX troubleshooting

Apply a RF-cable to the RF-connector to allow the transmitted signal to act as normal. RF-cable should be connected to measurement equipment or to at least a 10-dB attenuator, otherwise the PA may be damaged.

<u>Action</u>	<u>Keystrokes</u>
Start Wintelsa-Service-Software and	
Select: <u>P</u> roduct	Alt+p
<u>B</u> and	b
<u>G</u> SM g	
Select: <u>T</u> esting	Alt+e
<u>R</u> F Controls	r
<u>T</u> X Power Level : BASE	Alt+x, b
TX <u>C</u> ontinuos	Alt+c
TX <u>D</u> ata Type: Random	Alt+d, r
<u>C</u> hannel: 38	Alt+n, 38
<u>A</u> pply	Alt+a

Path of the transmitted EGSM signal

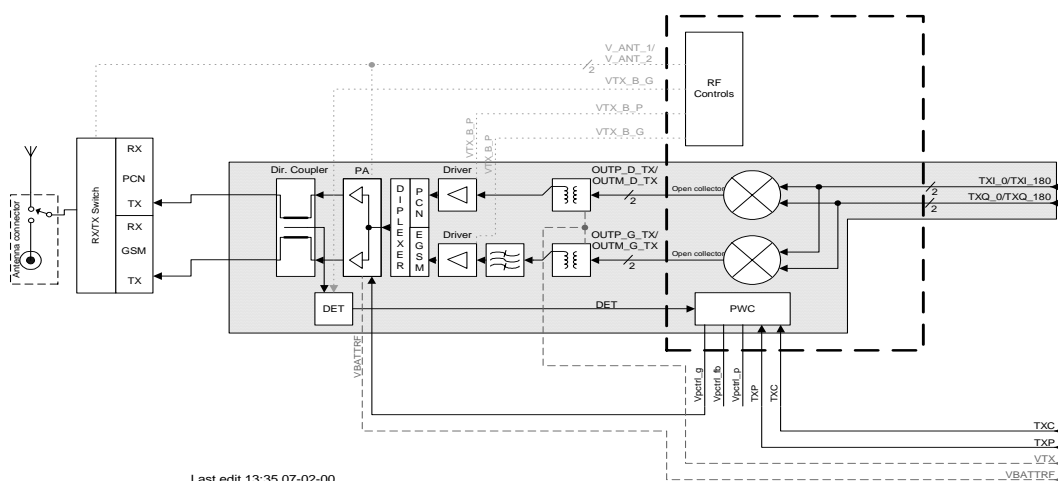
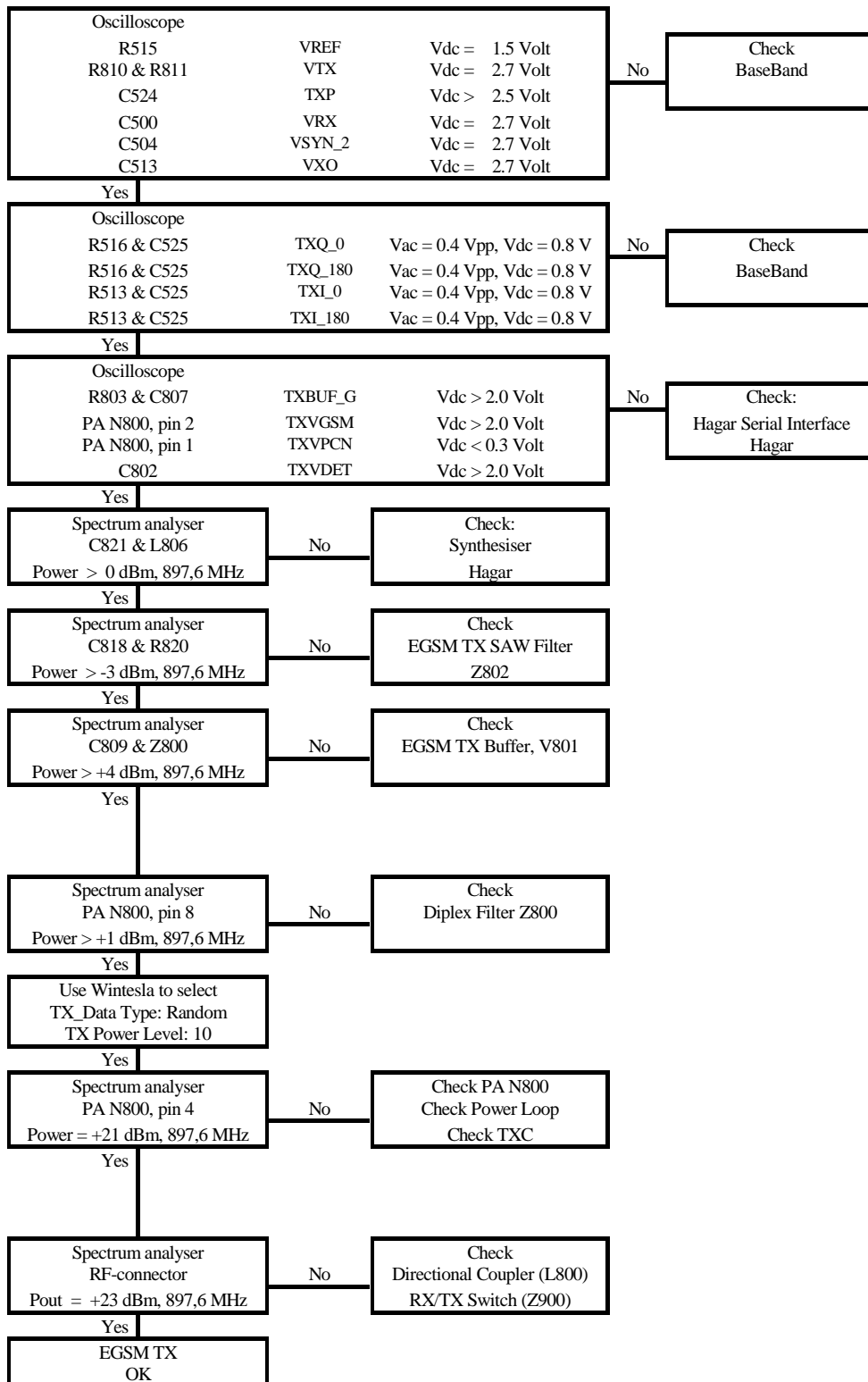

Figure 13: Transmitted EGSM signal

Faultfinding Chart for EGSM transmitter



PCN Transmitter

General instructions for PCN TX troubleshooting

Apply a RF-cable to the RF-connector to allow the transmitted signal act as normal. RF-cable should be connected to measurement equipment or to at least a 10-dB attenuator, otherwise the PA may be damaged.

Action

Keystrokes

Start Wintesla-Service-Software and

Select: <u>P</u> roduct	Alt+p
<u>B</u> and	b
<u>P</u> CN	p
Select: <u>T</u> esting	Alt+e
<u>R</u> F Controls	r
<u>T</u> X Power Level: BASE	Alt+x, b
TX <u>C</u> ontinuos	Alt+c
TX <u>D</u> ata Type: Random	Alt+d, r
Channel: <u>7</u> 00	Alt+n, 700
Apply	Alt+a

Path of the transmitted PCN signal

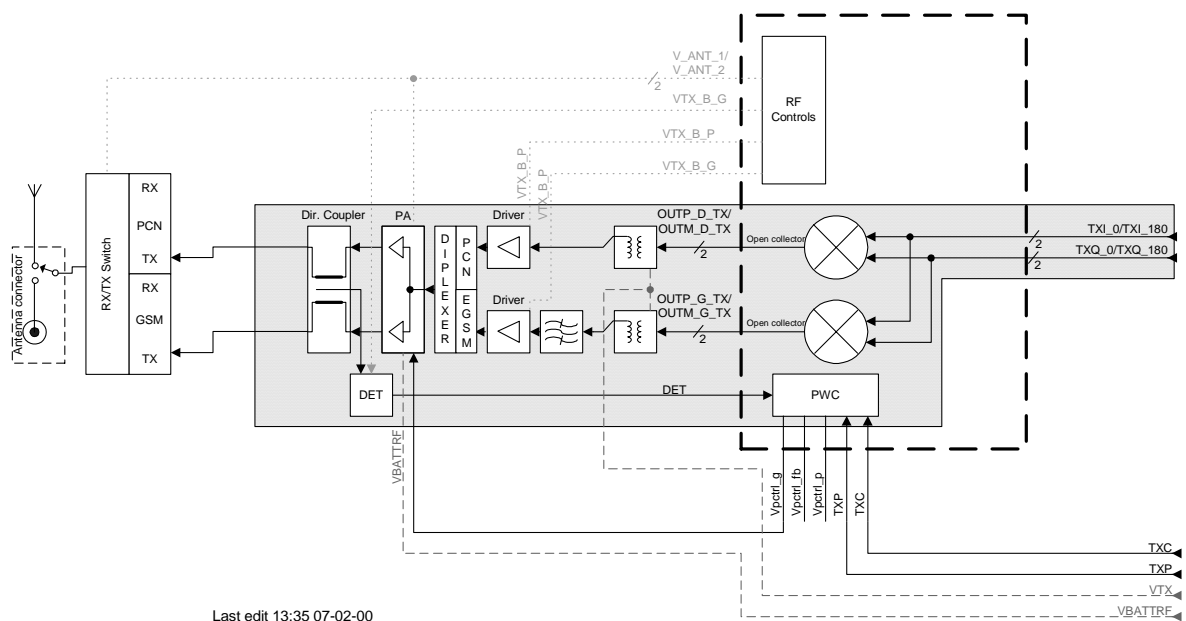

Fault finding chart for PCN transmitter

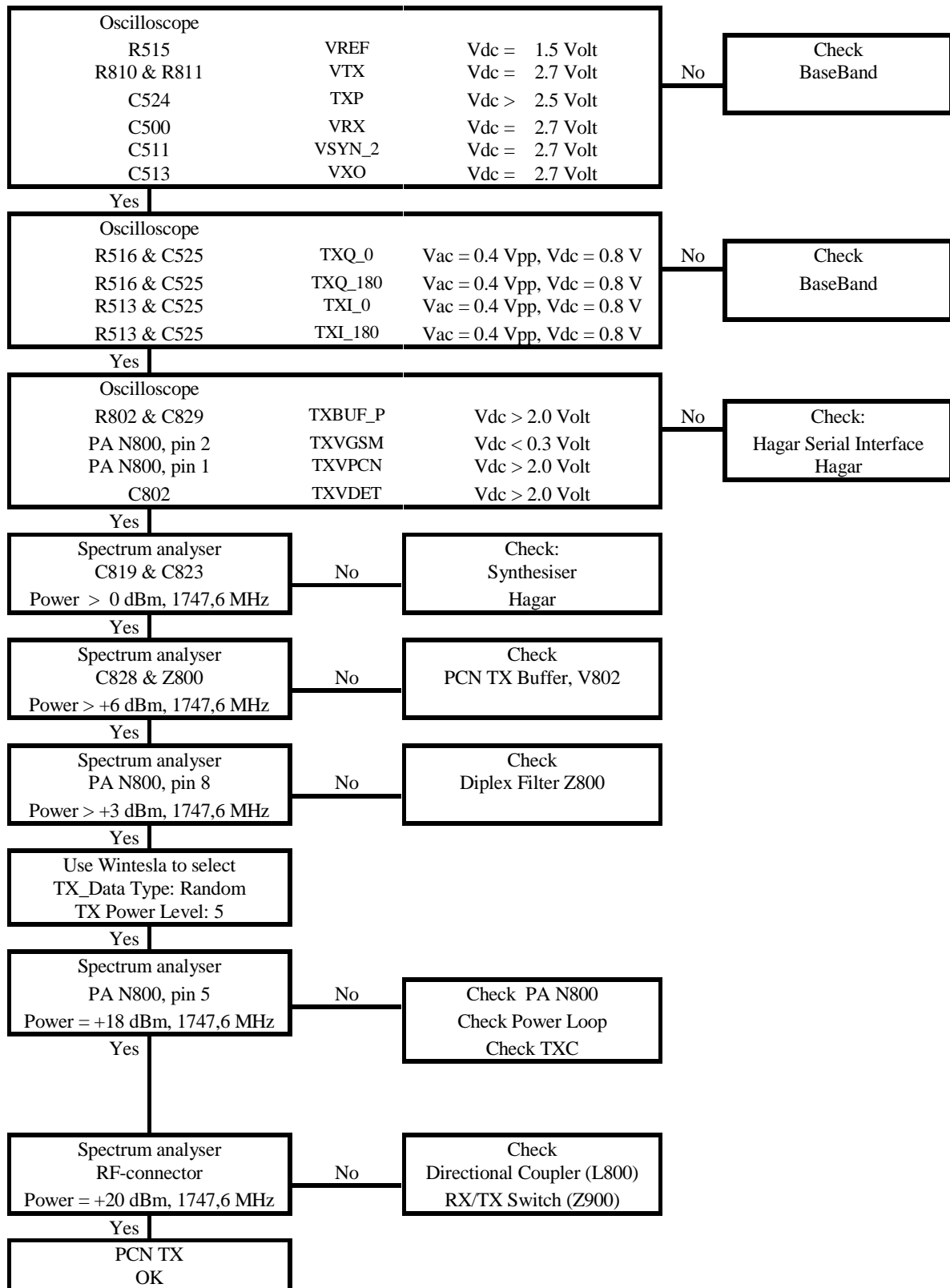

Synthesiser

There is only one PLL synthesiser generating frequencies for both Rx and Tx in both bands (PCN and GSM). VCO frequency is divided by 2 or by 4 in HAGAR depending on which band is active.

General instructions for Synthesiser troubleshooting

<u>Action</u>	<u>Keystrokes</u>
Start Wintesla-Service-Software and	
Select: <u>P</u> roduct	Alt+p
Band	b
<u>E</u> GSMe	
Select: <u>T</u> esting	Alt+e
<u>R</u> F Controls	r
<u>R</u> X Continuous	Alt+r
C <u>o</u> nt. Mode Ch: 60	Alt+o, 60

In this situation there is possible to measure frequency of 3788 MHz at the output of the VCO (G600) using a spectrum analyzer.

26 MHz reference oscillator (VCTCXO)

The 26 MHz oscillator (G602) is used as a reference frequency for the PLL synthesiser and as the system clock for BB (13 MHz) after it is divided by 2 in HAGAR. 26 MHz signal from the VCTCXO is approx. 0,8 Vpp. Frequency of this oscillator is adjusted by dc voltage (Vcon) coming from the DAC in COBBA. Range of Vcon is 0.3 – 2.3 V.

VCO

The VCO is generating frequencies in the range of 3420 – 3840 MHz when PLL is in function. These are divided by 2 or by 4 in HAGAR so that they can generate all channels in GSM and PCN. Frequency of the VCO is controlled by dc voltage (Vc) coming from the loop filter. Range of the Vc when PLL is in function is 0.7 – 3.8 V. Even if PLL is not working (Vc out of range) there is some frequency at the output of the VCO (G600) which is between 3 and 4 GHz, of course if the VCO is working.

Fault finding chart for PLL Synthesiser

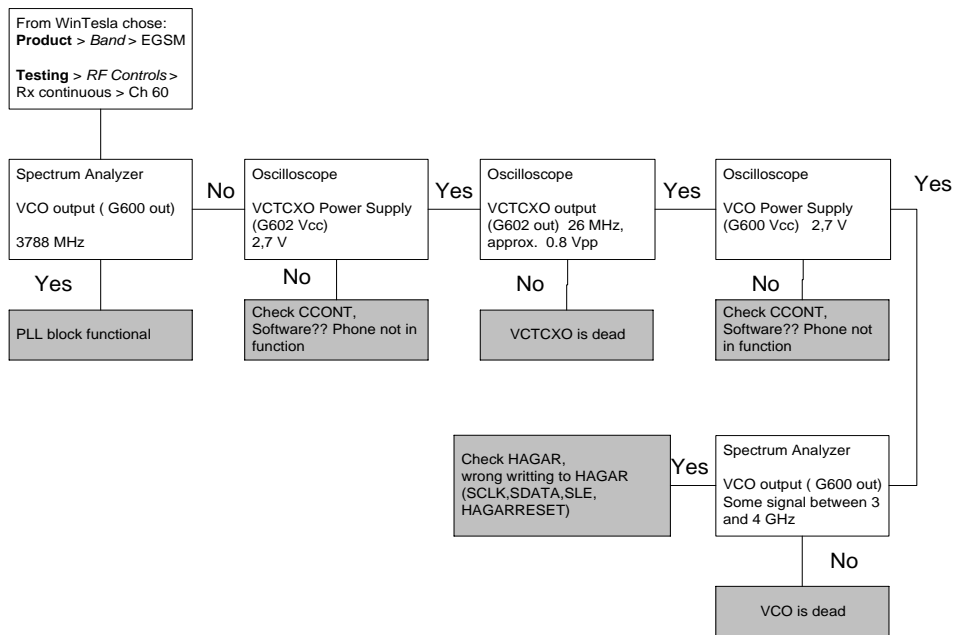

It is important to If the power supply for VCTCXO (VXO) is OFF only in 'Deep Sleep Mode' and power supply for VCO (G600 Vcc) is OFF in 'Sleep Mode'.

If the phone is 'dead' a very short time after the power is turned ON, possible reason for this might be that 13 MHz system clock signal is not coming to the BB. Use the following chart to find the problem.

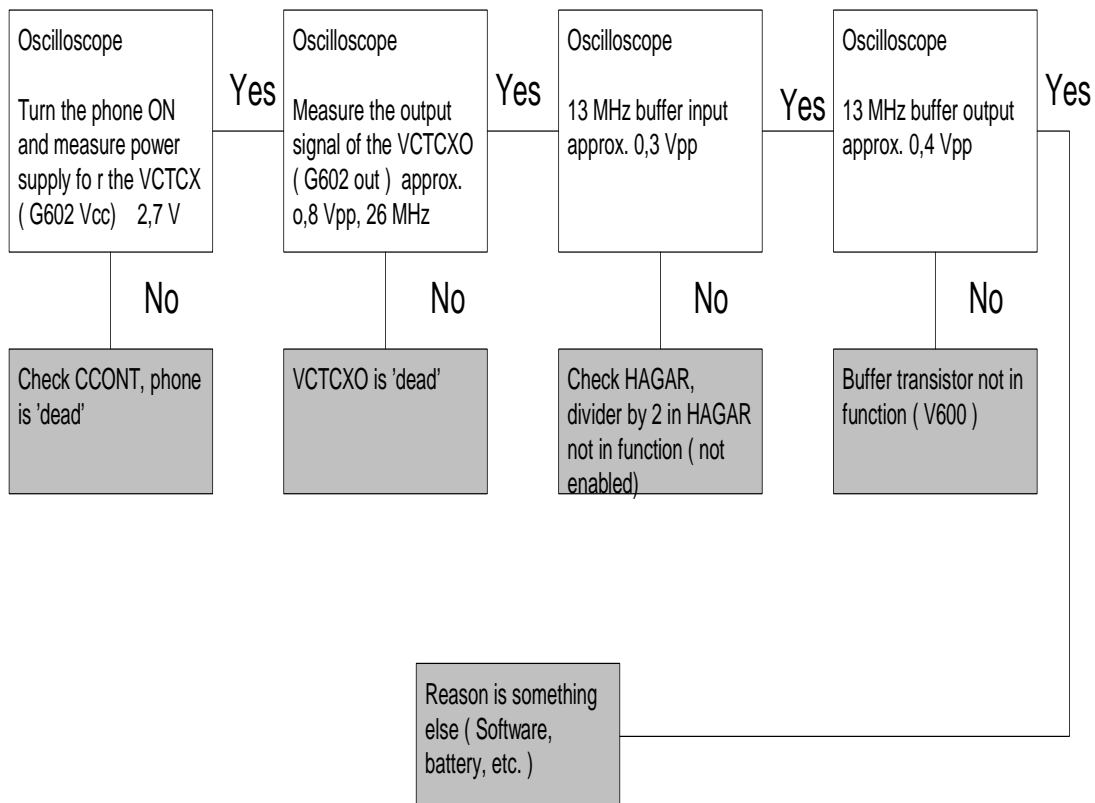

PLL Block diagram

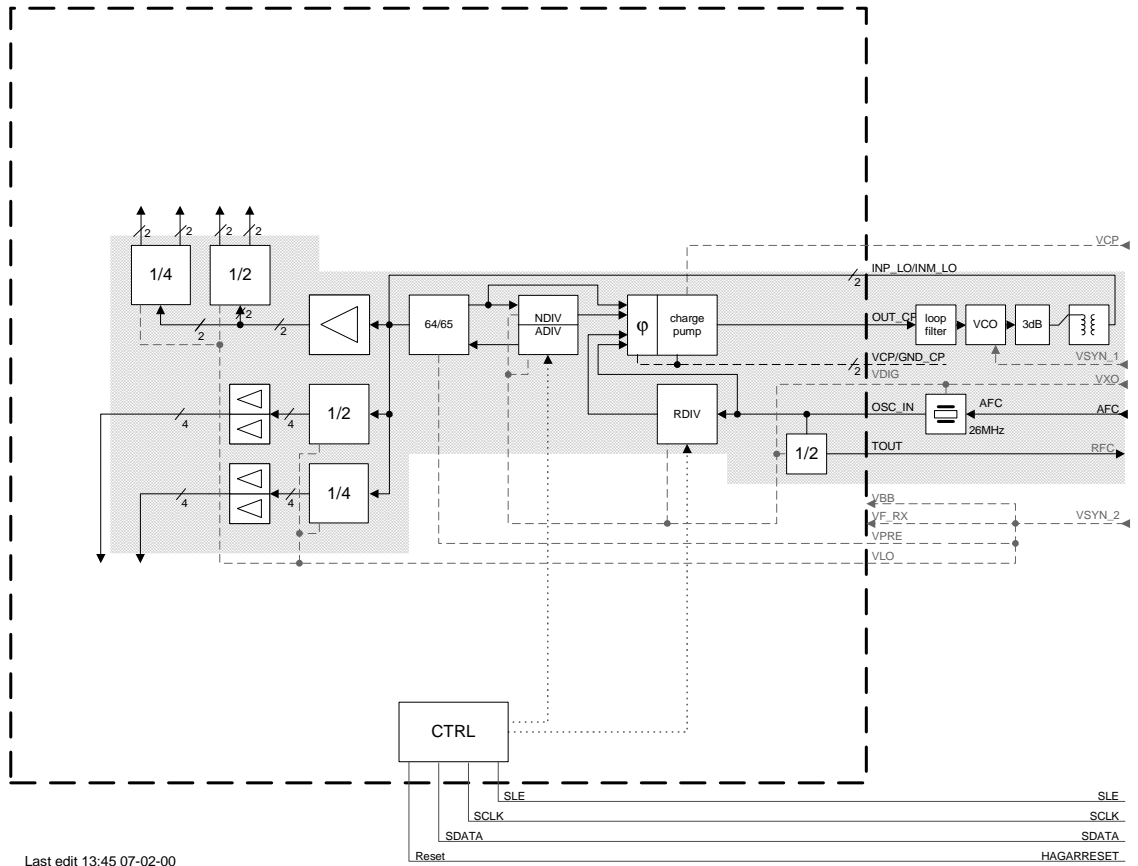

Frequency lists

EGSM

Frequency list NPE-3 EGSM														
CH	TX	RX	VCO TX	VCO RX	CH	TX	RX	VCO TX	VCO RX	CH	TX	RX	VCO TX	VCO RX
975	880.2	925.2	3520.8	3700.8	1	890.2	935.2	3560.8	3740.8	63	902.6	947.6	3610.4	3790.4
976	880.4	925.4	3521.6	3701.6	2	890.4	935.4	3561.6	3741.6	64	902.8	947.8	3611.2	3791.2
977	880.6	925.6	3522.4	3702.4	3	890.6	935.6	3562.4	3742.4	65	903	948	3612	3792
978	880.8	925.8	3523.2	3703.2	4	890.8	935.8	3563.2	3743.2	66	903.2	948.2	3612.8	3792.8
979	881	926	3524	3704	5	891	936	3564	3744	67	903.4	948.4	3613.6	3793.6
980	881.2	926.2	3524.8	3704.8	6	891.2	936.2	3564.8	3744.8	68	903.6	948.6	3614.4	3794.4
981	881.4	926.4	3525.6	3705.6	7	891.4	936.4	3565.6	3745.6	69	903.8	948.8	3615.2	3795.2
982	881.6	926.6	3526.4	3706.4	8	891.6	936.6	3566.4	3746.4	70	904	949	3616	3796
983	881.8	926.8	3527.2	3707.2	9	891.8	936.8	3567.2	3747.2	71	904.2	949.2	3616.8	3796.8
984	882	927	3528	3708	10	892	937	3568	3748	72	904.4	949.4	3617.6	3797.6
985	882.2	927.2	3528.8	3708.8	11	892.2	937.2	3568.8	3748.8	73	904.6	949.6	3618.4	3798.4
986	882.4	927.4	3529.6	3709.6	12	892.4	937.4	3569.6	3749.6	74	904.8	949.8	3619.2	3799.2
987	882.6	927.6	3530.4	3710.4	13	892.6	937.6	3570.4	3750.4	75	905	950	3620	3800
988	882.8	927.8	3531.2	3711.2	14	892.8	937.8	3571.2	3751.2	76	905.2	950.2	3620.8	3800.8
989	883	928	3532	3712	15	893	938	3572	3752	77	905.4	950.4	3621.6	3801.6
990	883.2	928.2	3532.8	3712.8	16	893.2	938.2	3572.8	3752.8	78	905.6	950.6	3622.4	3802.4
991	883.4	928.4	3533.6	3713.6	17	893.4	938.4	3573.6	3753.6	79	905.8	950.8	3623.2	3803.2
992	883.6	928.6	3534.4	3714.4	18	893.6	938.6	3574.4	3754.4	80	906	951	3624	3804
993	883.8	928.8	3535.2	3715.2	19	893.8	938.8	3575.2	3755.2	81	906.2	951.2	3624.8	3804.8
994	884	929	3536	3716	20	894	939	3576	3756	82	906.4	951.4	3625.6	3805.6
995	884.2	929.2	3536.8	3716.8	21	894.2	939.2	3576.8	3756.8	83	906.6	951.6	3626.4	3806.4
996	884.4	929.4	3537.6	3717.6	22	894.4	939.4	3577.6	3757.6	84	906.8	951.8	3627.2	3807.2
997	884.6	929.6	3538.4	3718.4	23	894.6	939.6	3578.4	3758.4	85	907	952	3628	3808
998	884.8	929.8	3539.2	3719.2	24	894.8	939.8	3579.2	3759.2	86	907.2	952.2	3628.8	3808.8
999	885	930	3540	3720	25	895	940	3580	3760	87	907.4	952.4	3629.6	3809.6
1000	885.2	930.2	3540.8	3720.8	26	895.2	940.2	3580.8	3760.8	88	907.6	952.6	3630.4	3810.4
1001	885.4	930.4	3541.6	3721.6	27	895.4	940.4	3581.6	3761.6	89	907.8	952.8	3631.2	3811.2
1002	885.6	930.6	3542.4	3722.4	28	895.6	940.6	3582.4	3762.4	90	908	953	3632	3812
1003	885.8	930.8	3543.2	3723.2	29	895.8	940.8	3583.2	3763.2	91	908.2	953.2	3632.8	3812.8
1004	886	931	3544	3724	30	896	941	3584	3764	92	908.4	953.4	3633.6	3813.6
1005	886.2	931.2	3544.8	3724.8	31	896.2	941.2	3584.8	3764.8	93	908.6	953.6	3634.4	3814.4
1006	886.4	931.4	3545.6	3725.6	32	896.4	941.4	3585.6	3765.6	94	908.8	953.8	3635.2	3815.2
1007	886.6	931.6	3546.4	3726.4	33	896.6	941.6	3586.4	3766.4	95	909	954	3636	3816
1008	886.8	931.8	3547.2	3727.2	34	896.8	941.8	3587.2	3767.2	96	909.2	954.2	3636.8	3816.8
1009	887	932	3548	3728	35	897	942	3588	3768	97	909.4	954.4	3637.6	3817.6
1010	887.2	932.2	3548.8	3728.8	36	897.2	942.2	3588.8	3768.8	98	909.6	954.6	3638.4	3818.4
1011	887.4	932.4	3549.6	3729.6	37	897.4	942.4	3589.6	3769.6	99	909.8	954.8	3639.2	3819.2
1012	887.6	932.6	3550.4	3730.4	38	897.6	942.6	3590.4	3770.4	100	910	955	3640	3820
1013	887.8	932.8	3551.2	3731.2	39	897.8	942.8	3591.2	3771.2	101	910.2	955.2	3640.8	3820.8
1014	888	933	3552	3732	40	898	943	3592	3772	102	910.4	955.4	3641.6	3821.6
1015	888.2	933.2	3552.8	3732.8	41	898.2	943.2	3592.8	3772.8	103	910.6	955.6	3642.4	3822.4
1016	888.4	933.4	3553.6	3733.6	42	898.4	943.4	3593.6	3773.6	104	910.8	955.8	3643.2	3823.2
1017	888.6	933.6	3554.4	3734.4	43	898.6	943.6	3594.4	3774.4	105	911	956	3644	3824
1018	888.8	933.8	3555.2	3735.2	44	898.8	943.8	3595.2	3775.2	106	911.2	956.2	3644.8	3824.8
1019	889	934	3556	3736	45	899	944	3596	3776	107	911.4	956.4	3645.6	3825.6
1020	889.2	934.2	3556.8	3736.8	46	899.2	944.2	3596.8	3776.8	108	911.6	956.6	3646.4	3826.4
1021	889.4	934.4	3557.6	3737.6	47	899.4	944.4	3597.6	3777.6	109	911.8	956.8	3647.2	3827.2
1022	889.6	934.6	3558.4	3738.4	48	899.6	944.6	3598.4	3778.4	110	912	957	3648	3828
1023	889.8	934.8	3559.2	3739.2	49	899.8	944.8	3599.2	3779.2	111	912.2	957.2	3648.8	3828.8
0	890	935	3560	3740	50	900	945	3600	3780	112	912.4	957.4	3649.6	3829.6
					51	900.2	945.2	3600.8	3780.8	113	912.6	957.6	3650.4	3830.4
					52	900.4	945.4	3601.6	3781.6	114	912.8	957.8	3651.2	3831.2
					53	900.6	945.6	3602.4	3782.4	115	913	958	3652	3832
					54	900.8	945.8	3603.2	3783.2	116	913.2	958.2	3652.8	3832.8
					55	901	946	3604	3784	117	913.4	958.4	3653.6	3833.6
					56	901.2	946.2	3604.8	3784.8	118	913.6	958.6	3654.4	3834.4
					57	901.4	946.4	3605.6	3785.6	119	913.8	958.8	3655.2	3835.2
					58	901.6	946.6	3606.4	3786.4	120	914	959	3656	3836
					59	901.8	946.8	3607.2	3787.2	121	914.2	959.2	3656.8	3836.8
					60	902	947	3608	3788	122	914.4	959.4	3657.6	3837.6
					61	902.2	947.2	3608.8	3788.8	123	914.6	959.6	3658.4	3838.4
					62	902.4	947.4	3609.6	3789.6	124	914.8	959.8	3659.2	3839.2

PCN

Frequency list NPE-3 PCN																			
CH	TX	RX	VCO TX	VCO RX	CH	TX	RX	VCO TX	VCO RX	CH	TX	RX	VCO TX	VCO RX	CH	TX	RX	VCO TX	VCO RX
512	1710.2	1805.2	3420.4	3610.4	606	1729	1824	3458	3648	700	1747.8	1842.8	3495.6	3685.6	794	1766.6	1861.6	3533.2	3723.2
513	1710.4	1805.4	3420.8	3610.8	607	1729.2	1824.2	3458.4	3648.4	701	1748	1843	3496	3686	795	1766.8	1861.8	3533.6	3723.6
514	1710.6	1805.6	3421.2	3611.2	608	1729.4	1824.4	3458.8	3648.8	702	1748.2	1843.2	3496.4	3686.4	796	1767	1862	3534	3724
515	1710.8	1805.8	3421.6	3611.6	609	1729.6	1824.6	3459.2	3649.2	703	1748.4	1843.4	3496.8	3686.8	797	1767.2	1862.2	3534.4	3724.4
516	1711	1806	3422	3612	610	1729.8	1824.8	3459.6	3649.6	704	1748.6	1843.6	3497.2	3687.2	798	1767.4	1862.4	3534.8	3724.8
517	1711.2	1806.2	3422.4	3612.4	611	1730	1825	3460	3650	705	1748.8	1843.8	3497.6	3687.6	799	1767.6	1862.6	3535.2	3725.2
518	1711.4	1806.4	3422.8	3612.8	612	1730.2	1825.2	3460.4	3650.4	706	1749	1844	3498	3688	800	1767.8	1862.8	3535.6	3725.6
519	1711.6	1806.6	3423.2	3613.2	613	1730.4	1825.4	3460.8	3650.8	707	1749.2	1844.2	3498.4	3688.4	801	1768	1863	3536	3726
520	1711.8	1806.8	3423.6	3613.6	614	1730.6	1825.6	3461.2	3651.2	708	1749.4	1844.4	3498.8	3688.8	802	1768.2	1863.2	3536.4	3726.4
521	1712	1807	3424	3614	615	1730.8	1825.8	3461.6	3651.6	709	1749.6	1844.6	3499.2	3689.2	803	1768.4	1863.4	3536.8	3726.8
522	1712.2	1807.2	3424.4	3614.4	616	1731	1826	3462	3652	710	1749.8	1844.8	3499.6	3689.6	804	1768.6	1863.6	3537.2	3727.2
523	1712.4	1807.4	3424.8	3614.8	617	1731.2	1826.2	3462.4	3652.4	711	1750	1845	3500	3690	805	1768.8	1863.8	3537.6	3727.6
524	1712.6	1807.6	3425.2	3615.2	618	1731.4	1826.4	3462.8	3652.8	712	1750.2	1845.2	3500.4	3690.4	806	1769	1864	3538	3728
525	1712.8	1807.8	3425.6	3615.6	619	1731.6	1826.6	3463.2	3653.2	713	1750.4	1845.4	3500.8	3690.8	807	1769.2	1864.2	3538.4	3728.4
526	1713	1808	3426	3616	620	1731.8	1826.8	3463.6	3653.6	714	1750.6	1845.6	3501.2	3691.2	808	1769.4	1864.4	3538.8	3728.8
527	1713.2	1808.2	3426.4	3616.4	621	1732	1827	3464	3654	715	1750.8	1845.8	3501.6	3691.6	809	1769.6	1864.6	3539.2	3729.2
528	1713.4	1808.4	3426.8	3616.8	622	1732.2	1827.2	3464.4	3654.4	716	1751	1846	3502	3692	810	1769.8	1864.8	3539.6	3729.6
529	1713.6	1808.6	3427.2	3617.2	623	1732.4	1827.4	3464.8	3654.8	717	1751.2	1846.2	3502.4	3692.4	811	1770	1865	3540	3730
530	1713.8	1808.8	3427.6	3617.6	624	1732.6	1827.6	3465.2	3655.2	718	1751.4	1846.4	3502.8	3692.8	812	1770.2	1865.2	3540.4	3730.4
531	1714	1809	3428	3618	625	1732.8	1827.8	3465.6	3655.6	719	1751.6	1846.6	3503.2	3693.2	813	1770.4	1865.4	3540.8	3730.8
532	1714.2	1809.2	3428.4	3618.4	626	1733	1828	3466	3656	720	1751.8	1846.8	3503.6	3693.6	814	1770.6	1865.6	3541.2	3731.2
533	1714.4	1809.4	3428.8	3618.8	627	1733.2	1828.2	3466.4	3656.4	721	1752	1847	3504	3694	815	1770.8	1865.8	3541.6	3731.6
534	1714.6	1809.6	3429.2	3619.2	628	1733.4	1828.4	3466.8	3656.8	722	1752.2	1847.2	3504.4	3694.4	816	1771	1866	3542	3732
535	1714.8	1809.8	3429.6	3619.6	629	1733.6	1828.6	3467.2	3657.2	723	1752.4	1847.4	3504.8	3694.8	817	1771.2	1866.2	3542.4	3732.4
536	1715	1810	3430	3620	630	1733.8	1828.8	3467.6	3657.6	724	1752.6	1847.6	3505.2	3695.2	818	1771.4	1866.4	3542.8	3732.8
537	1715.2	1810.2	3430.4	3620.4	631	1734	1829	3468	3658	725	1752.8	1847.8	3505.6	3695.6	819	1771.6	1866.6	3543.2	3733.2
538	1715.4	1810.4	3430.8	3620.8	632	1734.2	1829.2	3468.4	3658.4	726	1753	1848	3506	3696	820	1771.8	1866.8	3543.6	3733.6
539	1715.6	1810.6	3431.2	3621.2	633	1734.4	1829.4	3468.8	3658.8	727	1753.2	1848.2	3506.4	3696.4	821	1772	1867	3544	3734
540	1715.8	1810.8	3431.6	3621.6	634	1734.6	1829.6	3469.2	3659.2	728	1753.4	1848.4	3506.8	3696.8	822	1772.2	1867.2	3544.4	3734.4
541	1716	1811	3432	3622	635	1734.8	1829.8	3469.6	3659.6	729	1753.6	1848.6	3507.2	3697.2	823	1772.4	1867.4	3544.8	3734.8
542	1716.2	1811.2	3432.4	3622.4	636	1735	1830	3470	3660	730	1753.8	1848.8	3507.6	3697.6	824	1772.6	1867.6	3545.2	3735.2
543	1716.4	1811.4	3432.8	3622.8	637	1735.2	1830.2	3470.4	3660.4	731	1754	1849	3508	3698	825	1772.8	1867.8	3545.6	3735.6
544	1716.6	1811.6	3433.2	3623.2	638	1735.4	1830.4	3470.8	3660.8	732	1754.2	1849.2	3508.4	3698.4	826	1773	1868	3546	3736
545	1716.8	1811.8	3433.6	3623.6	639	1735.6	1830.6	3471.2	3661.2	733	1754.4	1849.4	3508.8	3698.8	827	1773.2	1868.2	3546.4	3736.4
546	1717	1812	3434	3624	640	1735.8	1830.8	3471.6	3661.6	734	1754.6	1849.6	3509.2	3699.2	828	1773.4	1868.4	3546.8	3736.8
547	1717.2	1812.2	3434.4	3624.4	641	1736	1831	3472	3662	735	1754.8	1849.8	3509.6	3699.6	829	1773.6	1868.6	3547.2	3737.2
548	1717.4	1812.4	3434.8	3624.8	642	1736.2	1831.2	3472.4	3662.4	736	1755	1850	3510	3700	830	1773.8	1868.8	3547.6	3737.6
549	1717.6	1812.6	3435.2	3625.2	643	1736.4	1831.4	3472.8	3662.8	737	1755.2	1850.2	3510.4	3700.4	831	1774	1869	3548	3738
550	1717.8	1812.8	3435.6	3625.6	644	1736.6	1831.6	3473.2	3663.2	738	1755.4	1850.4	3510.8	3700.8	832	1774.2	1869.2	3548.4	3738.4
551	1718	1813	3436	3626	645	1736.8	1831.8	3473.6	3663.6	739	1755.6	1850.6	3511.2	3701.2	833	1774.4	1869.4	3548.8	3738.8
552	1718.2	1813.2	3436.4	3626.4	646	1737	1832	3474	3664	740	1755.8	1850.8	3511.6	3701.6	834	1774.6	1869.6	3549.2	3739.2
553	1718.4	1813.4	3436.8	3626.8	647	1737.2	1832.2	3474.4	3664.4	741	1756	1851	3512	3702	835	1774.8	1869.8	3549.6	3739.6
554	1718.6	1813.6	3437.2	3627.2	648	1737.4	1832.4	3474.8	3664.8	742	1756.2	1851.2	3512.4	3702.4	836	1775	1870	3550	3740
555	1718.8	1813.8	3437.6	3627.6	649	1737.6	1832.6	3475.2	3665.2	743	1756.4	1851.4	3512.8	3702.8	837	1775.2	1870.2	3550.4	3740.4
556	1719	1814	3438	3628	650	1737.8	1832.8	3475.6	3665.6	744	1756.6	1851.6	3513.2	3703.2	838	1775.4	1870.4	3550.8	3740.8
557	1719.2	1814.2	3438.4	3628.4	651	1738	1833	3476	3666	745	1756.8	1851.8	3513.6	3703.6	839	1775.6	1870.6	3551.2	3741.2
558	1719.4	1814.4	3438.8	3628.8	652	1738.2	1833.2	3476.4	3666.4	746	1757	1852	3514	3704	840	1775.8	1870.8	3551.6	3741.6
559	1719.6	1814.6	3439.2	3629.2	653	1738.4	1833.4	3476.8	3666.8	747	1757.2	1852.2	3514.4	3704.4	841	1776	1871	3552	3742
560	1719.8	1814.8	3439.6	3629.6	654	1738.6	1833.6	3477.2	3667.2	748	1757.4	1852.4	3514.8	3704.8	842	1776.2	1871.2	3552.4	3742.4
561	1720	1815	3440	3630	655	1738.8	1833.8	3477.6	3667.6	749	1757.6	1852.6	3515.2	3705.2	843	1776.4	1871.4	3552.8	3742.8
562	1720.2	1815.2	3440.4	3630.4	656	1739	1834	3478	3668	750	1757.8	1852.8	3515.6	3705.6	844	1776.6	1871.6	3553.2	3743.2
563	1720.4	1815.4	3440.8	3630.8	657	1739.2	1834.2	3478.4	3668.4	751	1758	1853	3516	3706	845	1776.8	1871.8	3553.6	3743.6
564	1720.6	1815.6	3441.2	3631.2	658	1739.4	1834.4	3478.8	3668.8	752	1758.2	1853.2	3516.4	3706.4	846	1777	1872	3554	3744
565	1720.8	1815.8	3441.6	3631.6	659	1739.6	1834.6	3479.2	3669.2	753	1758.4	1853.4	3516.8	3706.8	847	1777.2	1872.2	3554.4	3744.4
566	1721	1816	3442	3632	660	1739.8	1834.8	3479.6	3669.6	754	1758.6	1853.6	3517.2	3707.2	848	1777.4	1872.4	3554.8	3744.8
567	1721.2	1816.2	3442.4	3632.4	661	1740	1835	3480	3670	755	1758.8	1853.8	3517.6	3707.6	849	1777.6	1872.6	3555.2	3745.2
568	1721.4	1816.4	3442.8	3632.8	662	1740.2	1835.2	3480.4	3670.4	756	1759	1854	3518	3708	850	1777.8	1872.8	3555.6	3745.6
569	1721.6	1816.6	3443.2	3633.2	663	1740.4	1835.4	3480.8	3670.8	757	1759.2	1854.2	3518.4	3708.4	851	1778	1873	3556	3746
570	1721.8	1816.8	3443.6	3633.6	664	174													

Wintesla tuning

Prior to any tuning the phone should be initialised:

Action

Keystrokes

Connect the phone to a PC with a DAU-9P cable	
Start Wintesla-Service-Software and	
Select <u>P</u> roduct	Alt+p
Open...NHM-3	
Select: <u>P</u> roduct	Alt+p
<u>I</u> nitialise	Alt+l
Normal Mode	F5

Which RF to tune after repairs

Different repairs require different tuning. In general it is necessary to determine in which section the repair was done to establish which tunings to perform. To determine if RF tuning is necessary after repair it is important that the functionality of the repaired circuit is understood well. In case the circuit is not fully understood it might be wise to play it safe and do RF tunings in accordance with the table below.

In general repairs in the TX part will require tuning of "TX Power" and "TX I/Q" tuning.

In general repairs in the RX part or PLL will always require "RX Calibration" and in some cases require AM Suppression tuning (Automatic) and RX Filter Calibration (Automatic).

Other parts interfacing to TX, RX or PLL might require tuning, but common sense should be used.

In the table below guidelines for what to tune when can be seen (if it can be ruled out that a component will change RF performance, e.g. the microphone B200 there is no need to do any RF tuning).

100-199	Yes				
200-299	Yes			Yes	Yes
D311	Yes	Yes	Yes	Yes	Yes
500-599	Yes	Yes	Yes	Yes	Yes
600-699	Yes				Yes
700-799	Yes	Yes			
800-899				Yes	Yes
900-999	Yes			Yes	Yes
Full Factory setting	Yes	Yes	Yes	Yes	Yes

RX Calibration

The "RX calibration" is used to determine gain at different gain-settings for front-end and Hagar and needs to be done in both bands, but the calibration has to be started once, it will automatically proceed to the PCN band after EGSM.

Action

Select: Tuning

RX Calibration

Keystroke

Alt+t

r

A window will pop-up

Note:

Default channel for RX(EGSM) tuning is 38
Frequency is 942.66771 MHz
This Tuning Channel can be edited in tesla.ini file

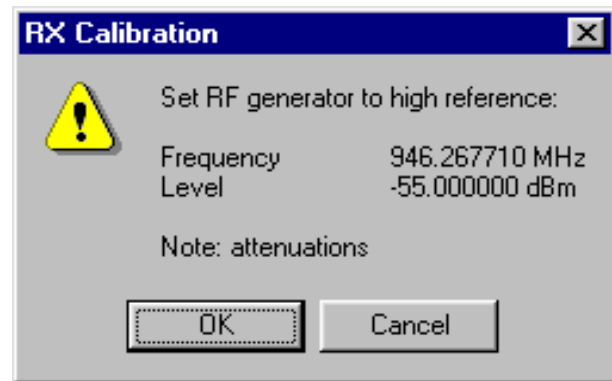

Note: Wintesla support DLLs must be 271.01.00 or later

Connect an external generator to the phone's RF connector and set the generator as the window tells you.

Click OK in the Wintesla window, now a new window pops up:

Note:

Default channel for RX(EGSM) tuning is 38
Frequency is 942.66771 MHz.
This Tuning Channel can be edited using tesla.ini file

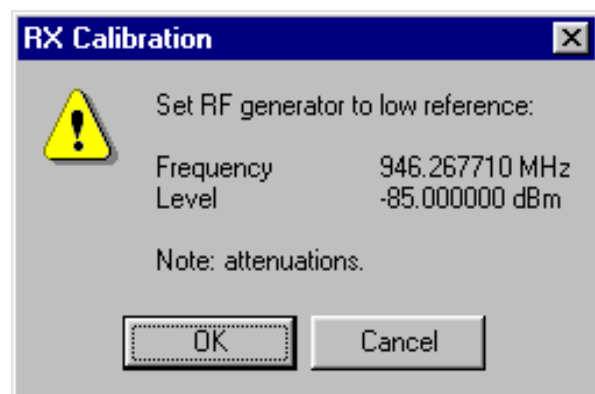

Change the level on the generator as the window tells you.

Click OK in the Wintesla window, now a new window pops up:

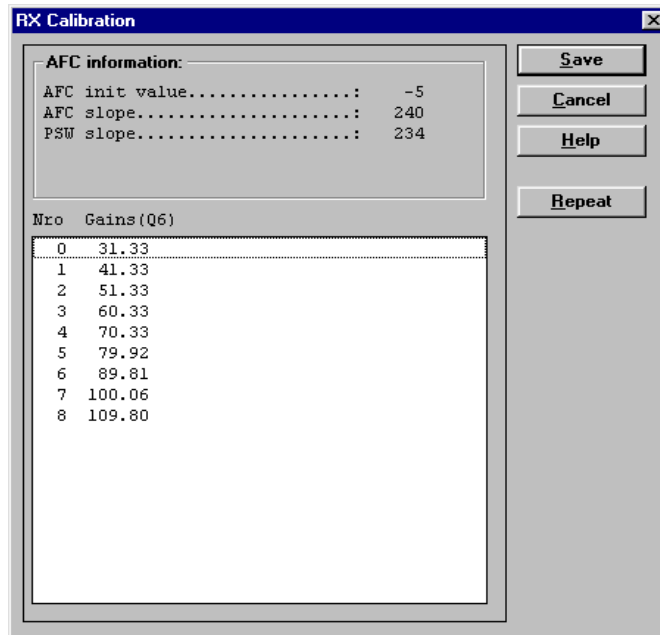

Click Save in the Wintesla window, now a new window pops up:

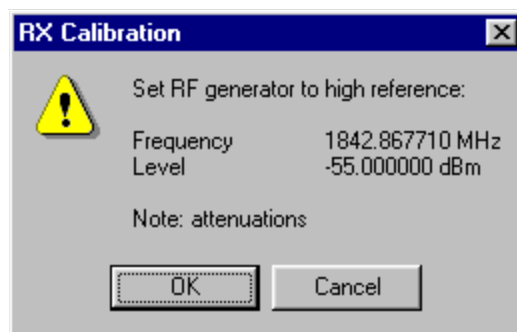

Change the level and frequency on the generator as the window tells you

Click OK in the Wintesla window, now a new window pops up:

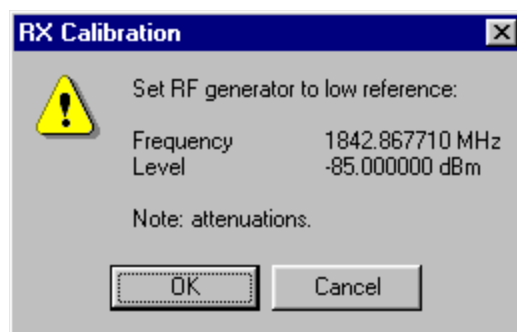

Change the level and frequency on the generator as the window tells you.

Click OK in the Wintesla window, now a new window pops up:

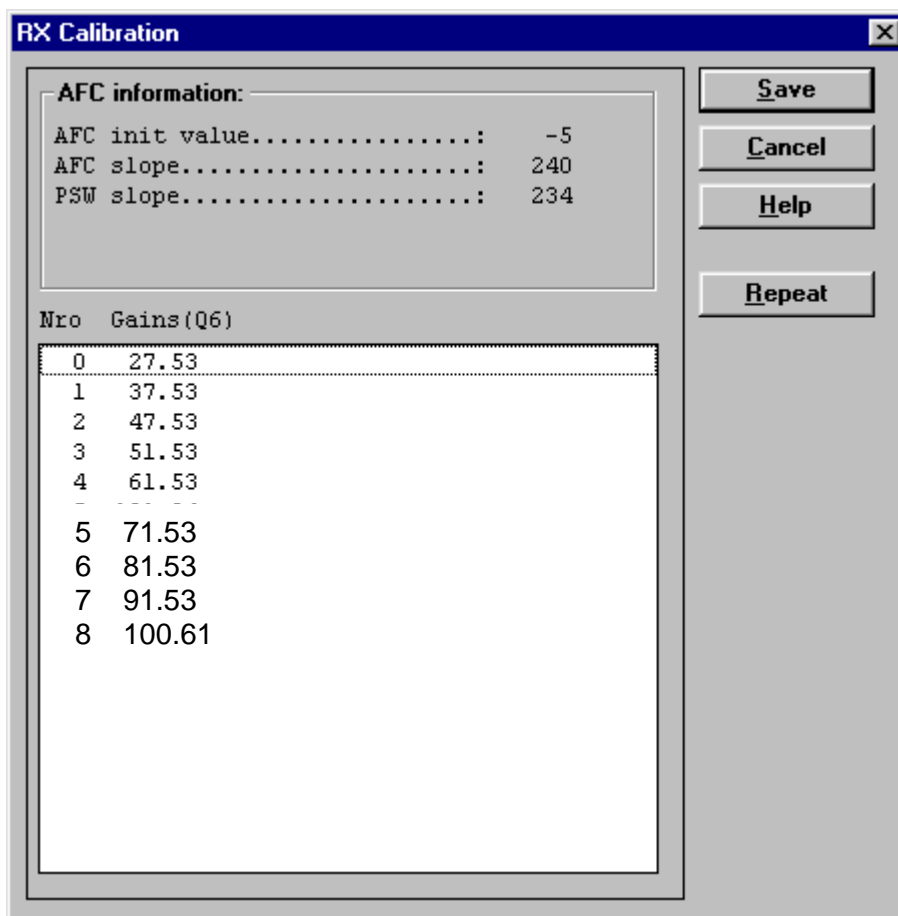

Click Save in the Wintesla window, RX Calibration is now completed.

RX Filter Calibration (Automatic)

This calibration is calibrating the Baseband filter inside Hagar, for this reason the calibration is not done in both bands.

Action

Keystroke

Select: Tuning

Alt+t

RX Measurements

A window now pops up:

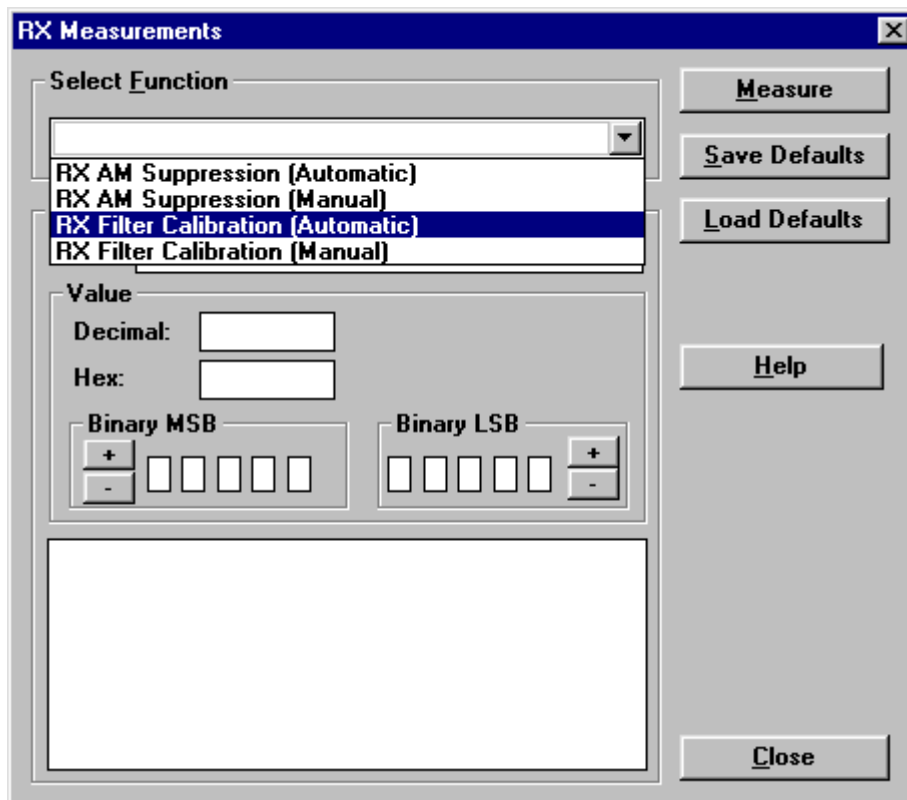

In the "Select Function" frame select RX "Filter calibration (Automatic)".

No external signal is needed for this, just click "Measure", wait a few seconds and then click "Save Defaults"

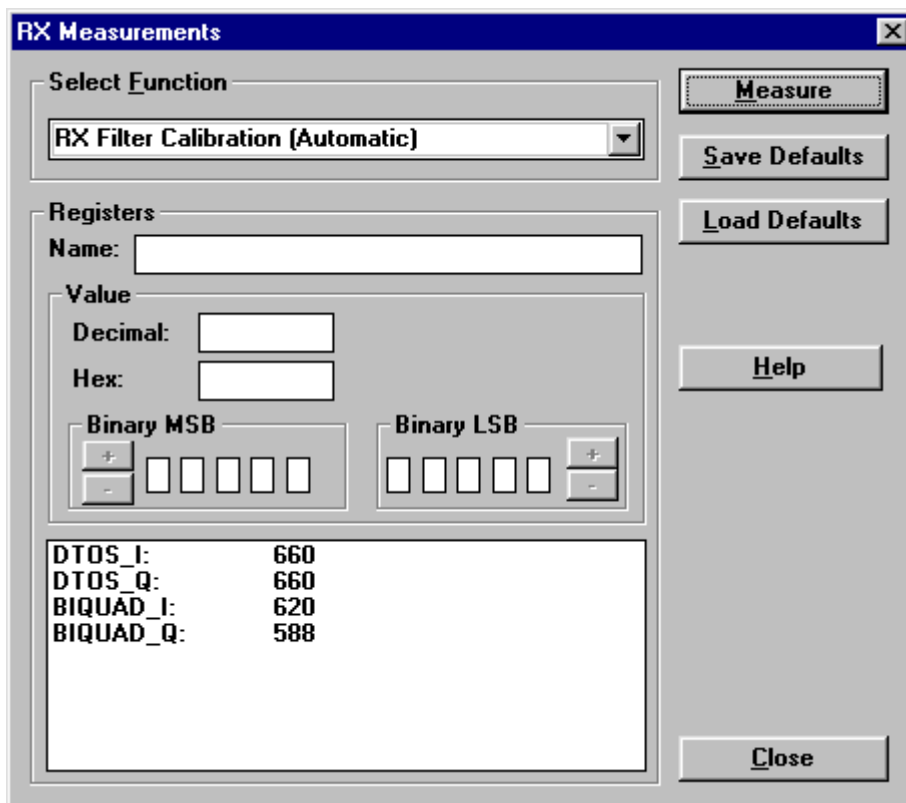

RX filter calibration is now completed and the "RX Measurements" window can be closed by clicking "Close"

RX AM Suppression (Automatic)

This calibration is tuning the AM suppression performance of Hagar mixers and will have to be done in both bands. If flash or Hagar have been replaced or Full Factory settings have been performed RX AM Suppression must be done.

EGSM

<u>Action</u>	<u>Keystroke</u>
Select: <u>P</u> roduct	Alt+p
<u>B</u> and	b
<u>E</u> GSM	e
Select: <u>T</u> uning	Alt+t
<u>R</u> X Measurements	

A window now pops up:

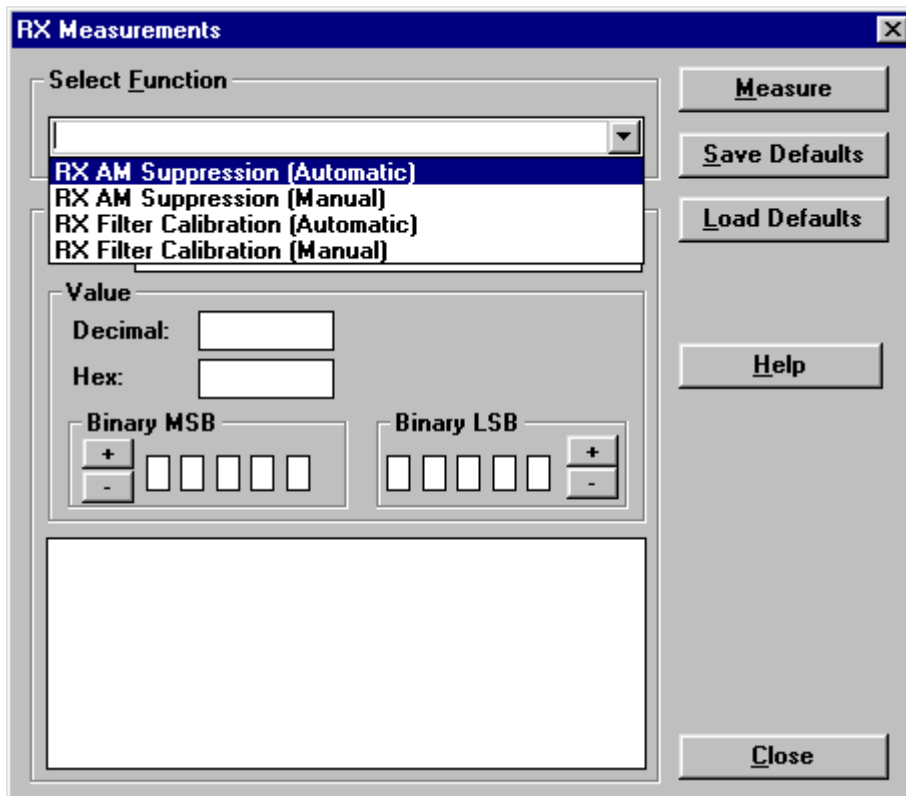

In the "Select Function" frame select RX "RX AM Suppression (Automatic)".

Click "Measure" and the following window pops up

NOTE: When using channel 38 for tuning, use Frequency 952.600 MHz for AM signal.

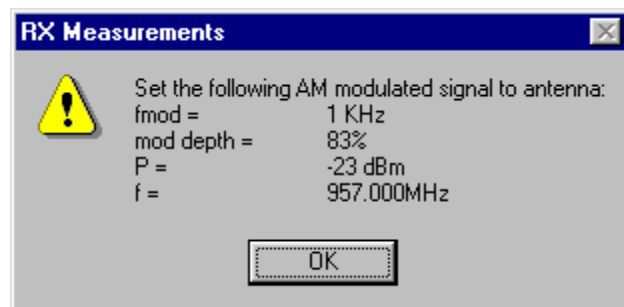

Connect an external generator to the antenna connector of the phone and set up the generator.

Click OK in the Wintesa window, the RSSI value is updated in RX Measurement window.

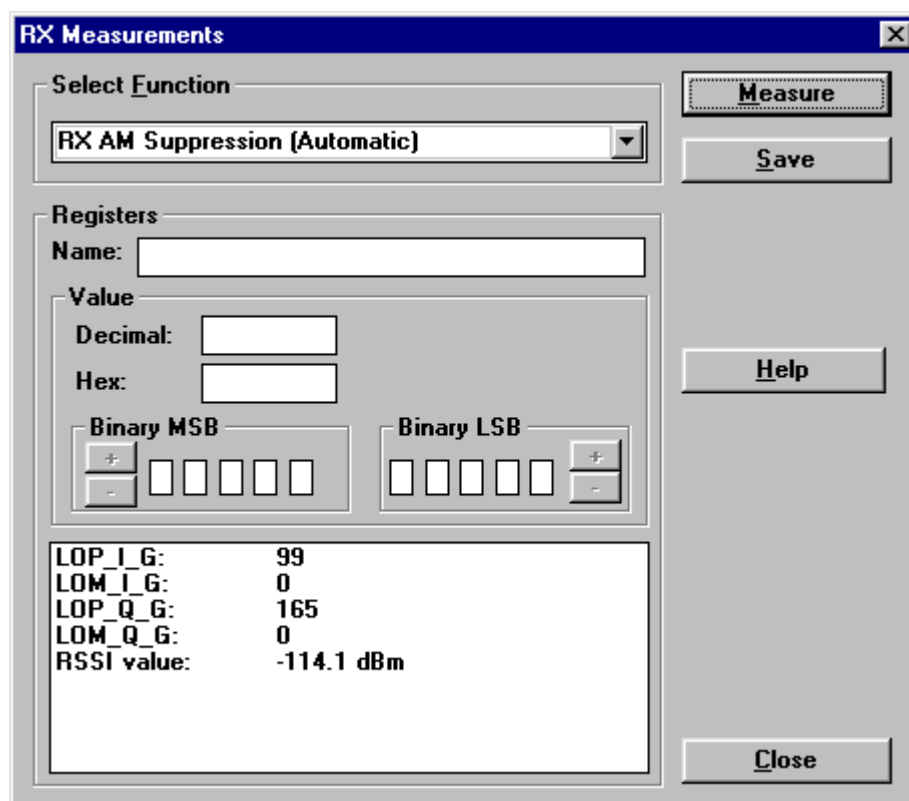

Click "Save ". The "RX AM suppression tuning" is now completed in EGSM.

PCN

Action

Keystroke

Select :Product

Alt+p

Band

b

PCN

p

Select:Tuning

Alt+t

RX Measurements

A window now pops-up:

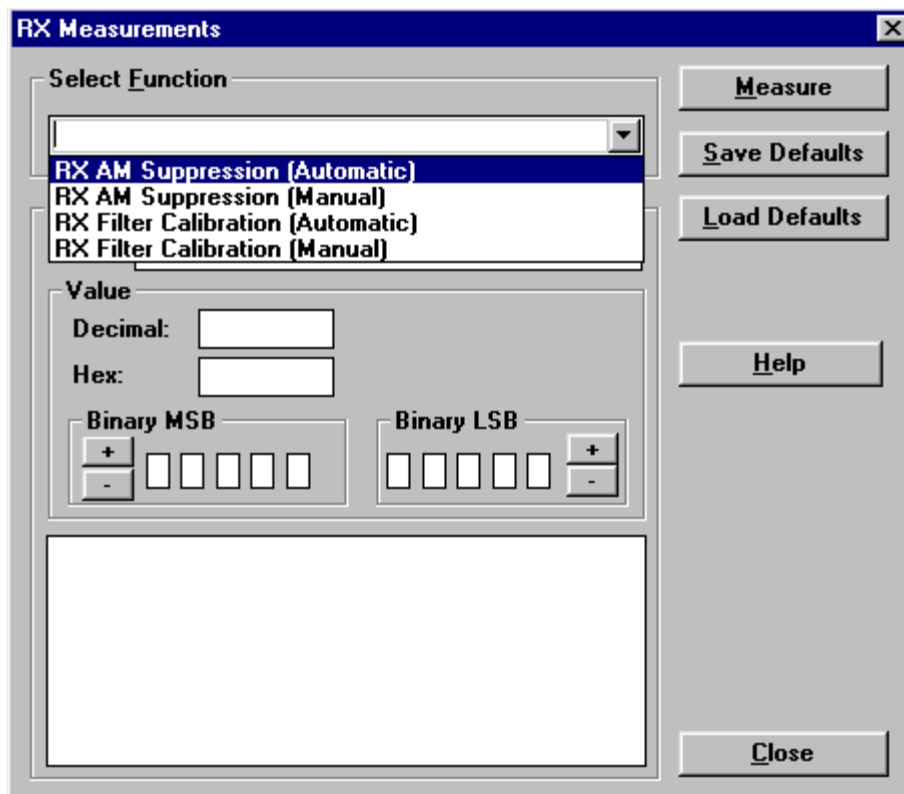

In the "Select Function" frame select RX "RX AM Suppression (Automatic)".

NOTE: Wintesa support DLLs must be 271.01.00 or later.

Click Measure, A window now pops up:

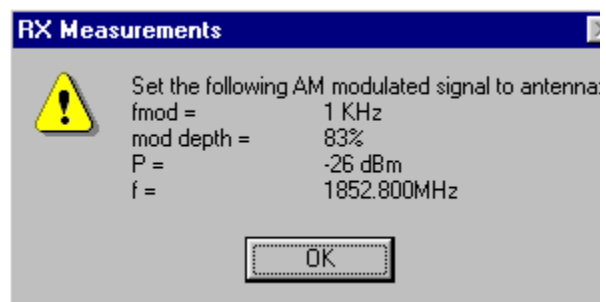

Connect an external generator to the antenna connector of the phone and set-up the generator.

Click OK in the Wintesla window, the RSSI value is updated in the RX Measurements window.

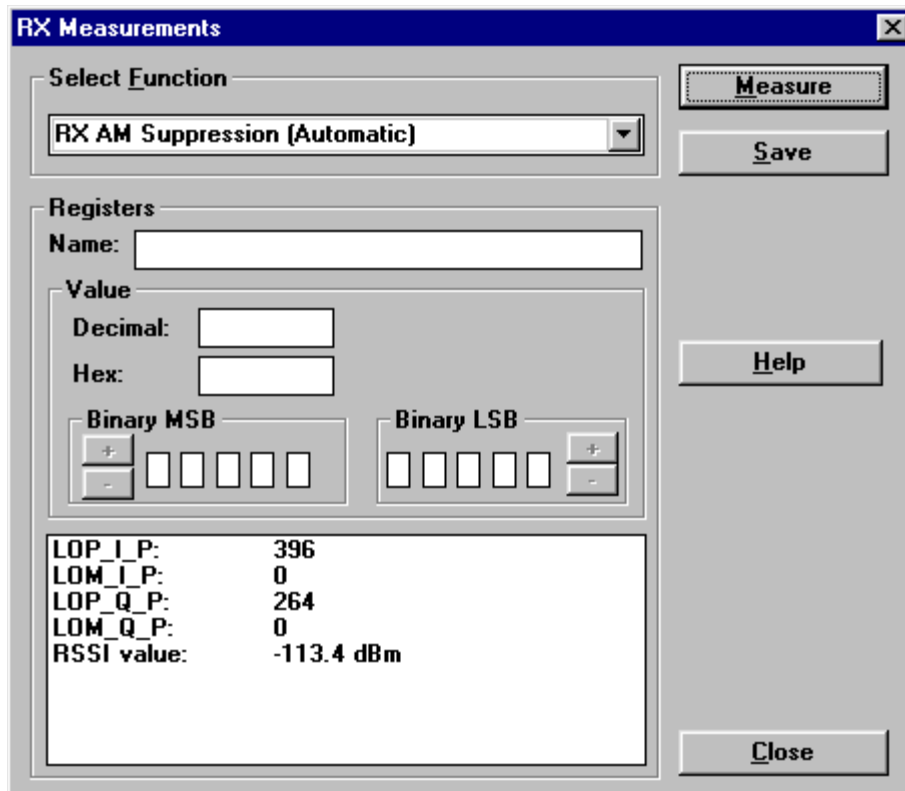

Click "Save ". The "RX AM suppression tuning" is now completed in PCN.

TX Power tuning

This tuning must be done in both bands.

Note: TX Power tuning must be done with a peak power meter, e.g. Rohde & Schwarz model NRVD with a Rohde & Schwarz Peak Power Sensor TDMA Model NRV-Z31 and a suitable attenuator.

The use of power meter in GSM testers is likely to cause larger error than the use of a dedicated power meter and might cause the phone to be non-compliant with GSM specifications.

EGSM

Action

Keystroke

Select: Product	Alt+p
<u>B</u> and	b
<u>E</u> GSM	e
Select: <u>T</u> esting	Alt+e
<u>R</u> F Controls	r

A window now pops up:

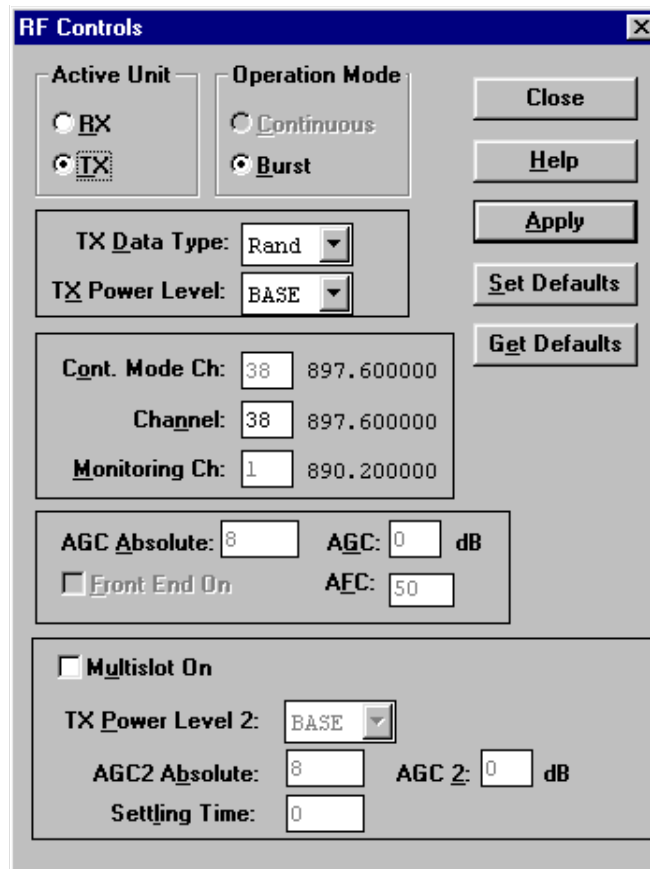

Action

Keystrokes

Set Active unit to IX

Set TX Data

Type: to Rand

Click Apply

Click Close

Select: Tuning

Alt+t

TX Power...

Alt+P

A window now pops up:

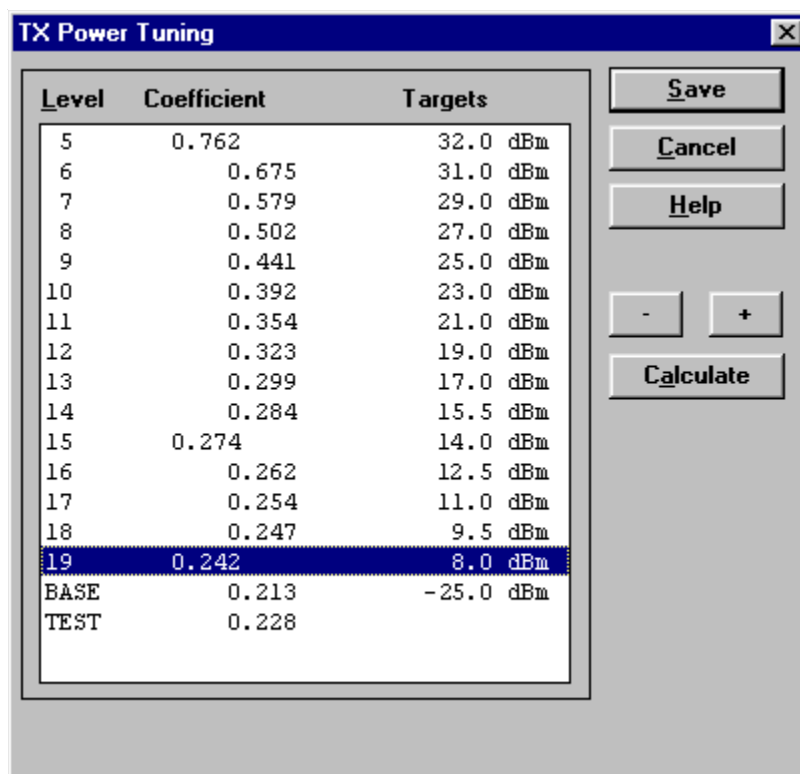

Tune level 19, 15, 5 and Base in accordance with the target values.

Click calculate.

Check if the other levels match the targets, correct if necessary.

Click Save when all values matches the targets.

PCN

Action

Keystrokes

Select: Product	Alt+p
<u>B</u> and	b
<u>P</u> CN	p
Select: <u>T</u> esting	Alt+e
<u>R</u> F Controls	r

A window now pops up:

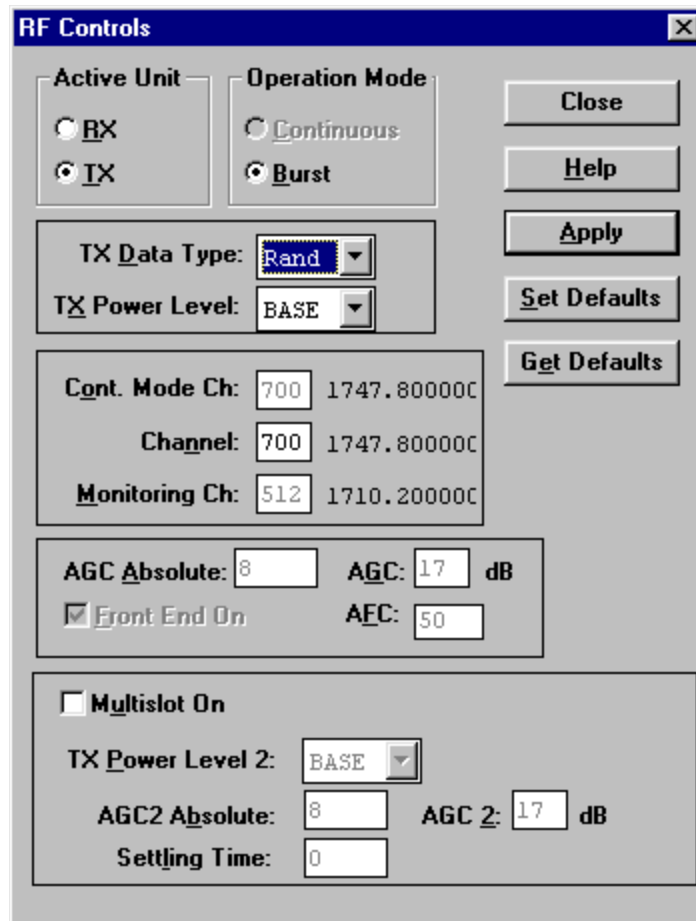

Action

Keystrokes

Set Active unit to <u>T</u> X	
Set TX <u>D</u> ata	Type: to Rand
Click <u>A</u> pply	
Click <u>C</u> lose	
Select: <u>T</u> uning	Alt+t
TX <u>P</u> ower...	Alt+P

A window now pops up:

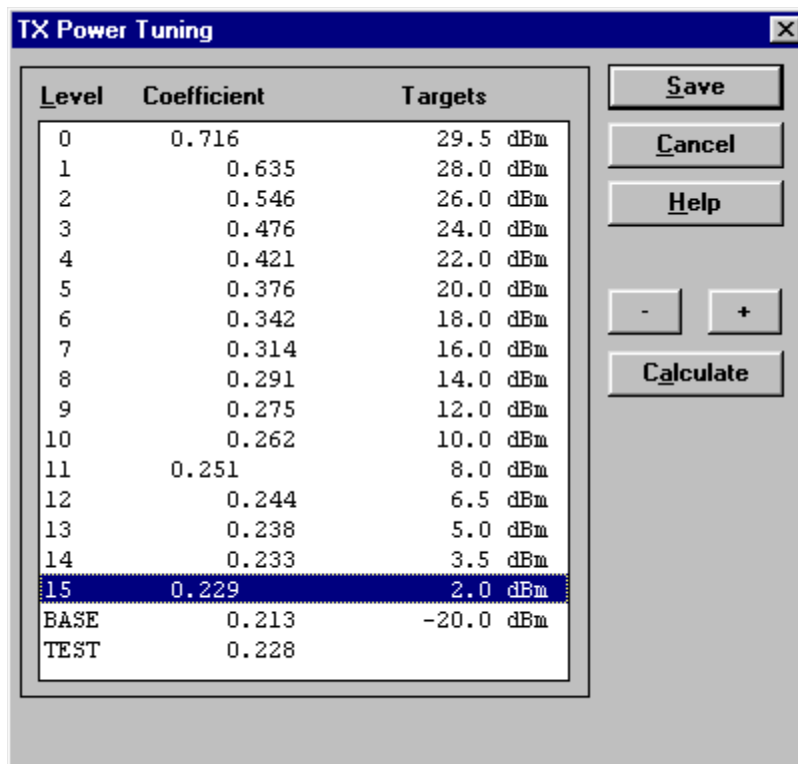

Tune level 15, 11, 0 and Base in accordance with the target values.

Click calculate.

Check if the other levels match the targets, correct if necessary.

Click Save when all values matches the targets.

TX I/Q Tuning

This tuning must be done in both bands

Initial set-up EGSM

Action

Keystrokes

Select: Product	Alt+p
<u>B</u> and	b
<u>E</u> GSM	e
Select: Testing	Alt+e
<u>R</u> F Controls	'r

A window now pops up:

<u>Action</u>	<u>Keystrokes</u>
Set Active unit to <u>I</u> X	
Set TX <u>D</u> ata	Type: to Cont1
Click <u>A</u> pply	
Click <u>C</u> lose	
Go through the "Common tuning procedure for EGSM and PCN" described in appropriate section of this document.	

Common tuning procedure for EGSM and PCN

<u>Action</u>	<u>Keystrokes</u>
Select: <u>T</u> uning	Alt+t
TX <u>I/Q</u> ...	Alt+q

A window now pops up:

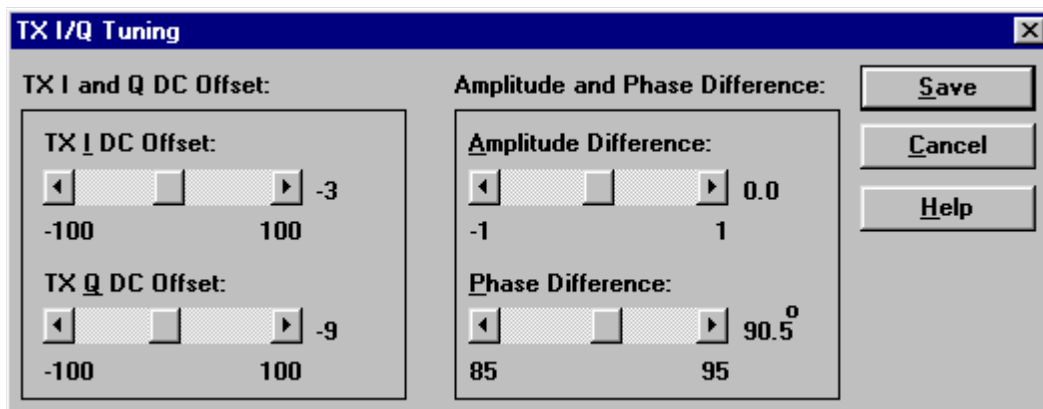

The carrier and +67kHz signal should now be tuned to a minimum.

The buttons in the "TX I and Q DC Offset:" will change the level of the carrier.

The buttons in the "Amplitude and Phase Difference:" window will change the level of the +67kHz signal. When minimum values are reached, click Save

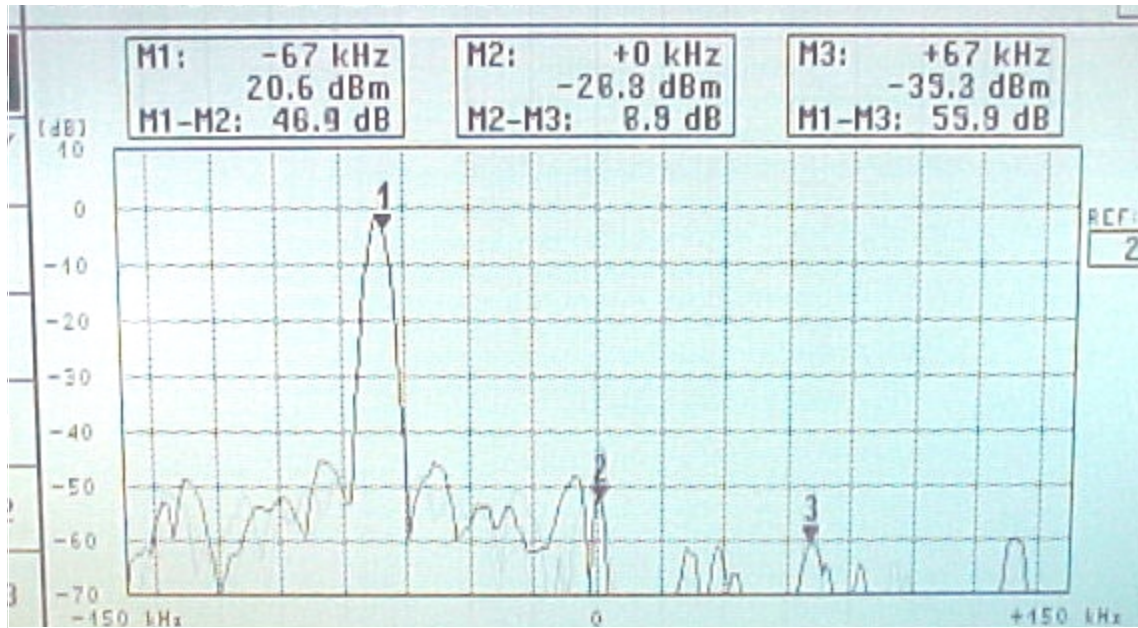

Ini-

tial set-up PCN

Action

Keystrokes

Select:Product

Alt+p

Band

b

PCN

p

Select:Testing

Alt+e

RF Controls

r

A window now pops up:

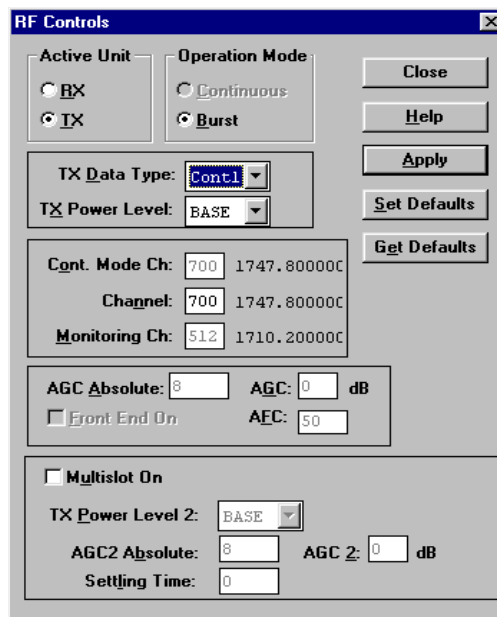

Set Active unit to IX

Set TX Data

Type: to Cont1

Click Apply

Click Close

Go through the "Common tuning procedure for EGSM and PCN" described earlier on in this chapter.